

DIRECTOR	GAVIN CAMERON-WEBB
DESIGNER	RUSSELL METHENY
TD	CHRIS NOBLE
DRAWN BY	NOBLE
WHILE WE WERE BOWLING STUDIO ARENA THEATRE 710 MAIN ST BUFFALO, NY 14202	
Project	PLAN
Date	1.22.04
Scale	1/2" = 1'-0"
Sheet	1

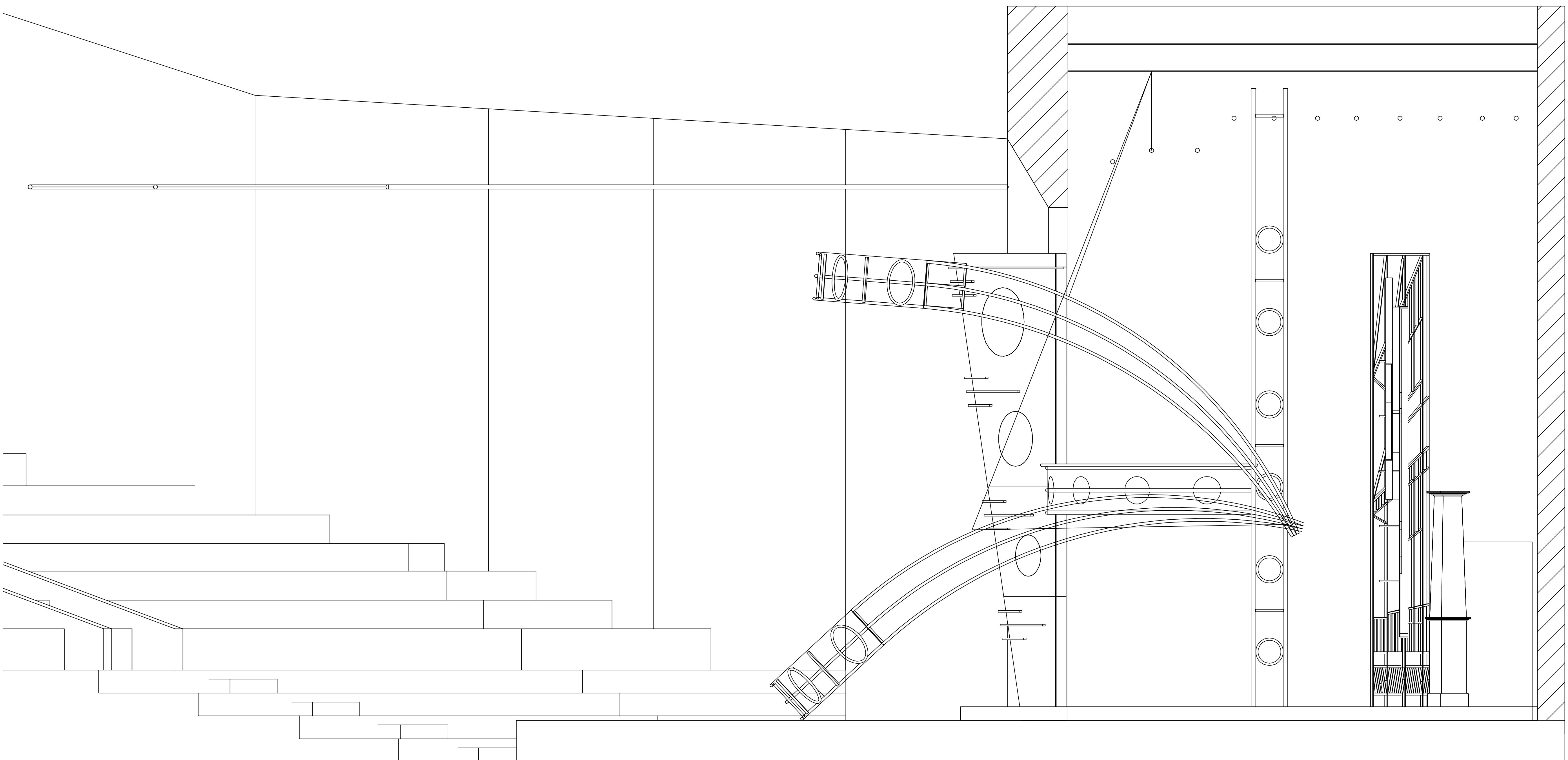

General Notes		
1		2/09
No.	Revision/Issue	Date
Firm Name and Address		
STUDIO ARENA THEATRE 710 MAIN ST. BUFFALO, NY 14202		
WHILE WE WERE BOWLING ALLEY CONFIGURATION SECTION		
Project	SECTION	Sheet
Date	2.09.04	2
Scale	1/2" = 1'-0"	

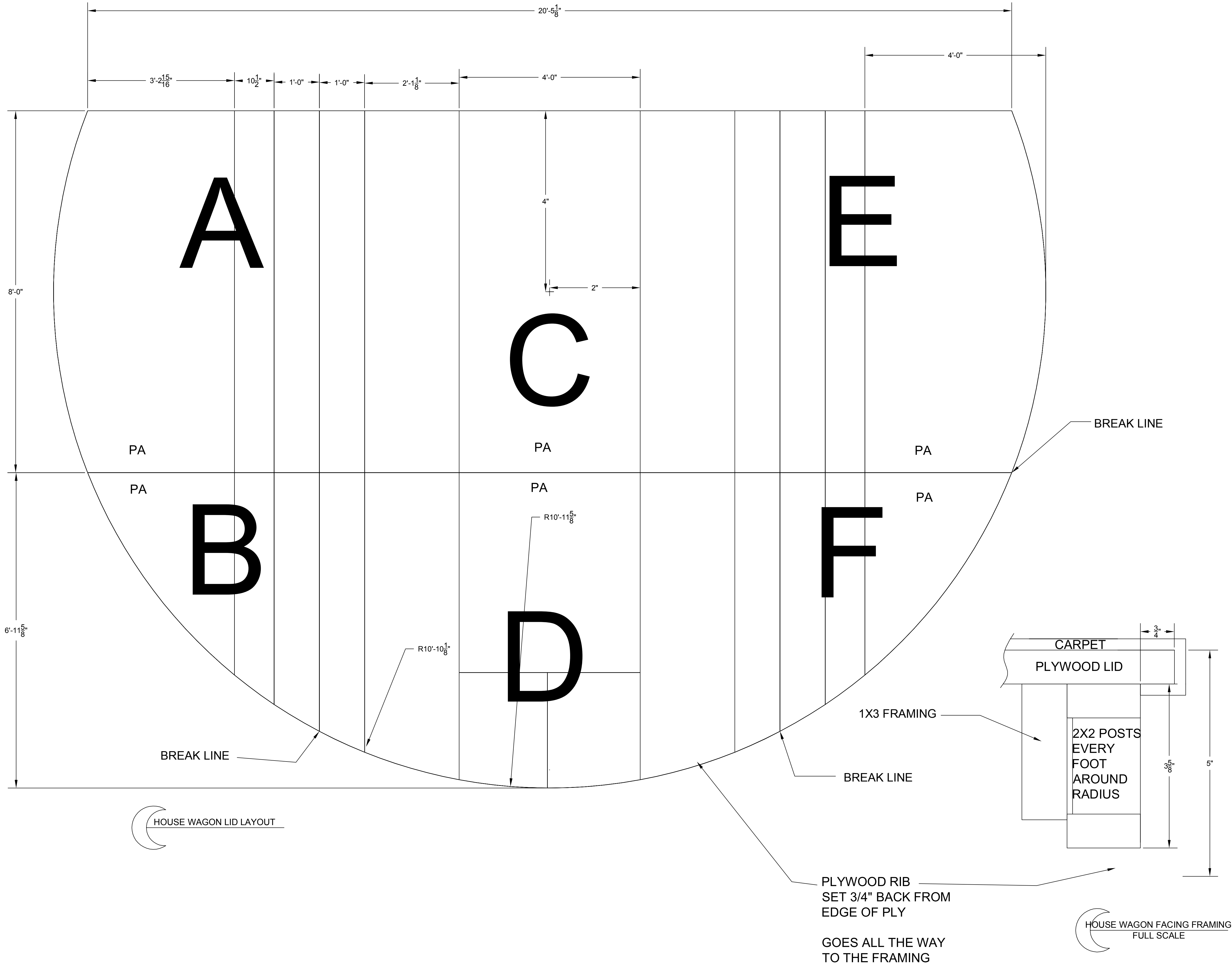

PA=PERMANENTLY ATTACHED

THESE PIECES OF LAUAN CAN BE LIQUID NAILED AND T-NAILED TO THE 1X3 METAL FRAME

ALL OTHER PLY LIDS NEED TO BE PREDRILLED AND SCREWED FOR EASY REMOVAL

THE FACING FRAMING NEEDS TO BREAK WHERE THE PLATFORMS DO

FACING WILL BE 1/8" DURON CUT AT 5" 6 STRIPS WILL BE NEEDED

MATERIALS:
 12 SHTS 18MM LAUAN
 1 2X4
 2 18MM LAUAN

DIRECTOR	GAVIN CAMERON-WEBB
DESIGNER	RUSSELL METHENY
ID	CHRIS NOBLE
DRAWN BY	AMY MYERS



WHILE WE WERE BOWLING
 HOUSE PLATFORM
 LID AND FACING FRAMING

STUDIO ARENA THEATRE
 710 MAIN ST
 BUFFALO, NY 14202

Project	HOUSE PLATFORM	Sheet	8
Date	1.20.04		
Scale	1"=1'-0"		

HOUSE WAGON LID LAYOUT

HOUSE WAGON FACING FRAMING FULL SCALE

PLYWOOD RIB SET 3/4" BACK FROM EDGE OF PLY
 GOES ALL THE WAY TO THE FRAMING

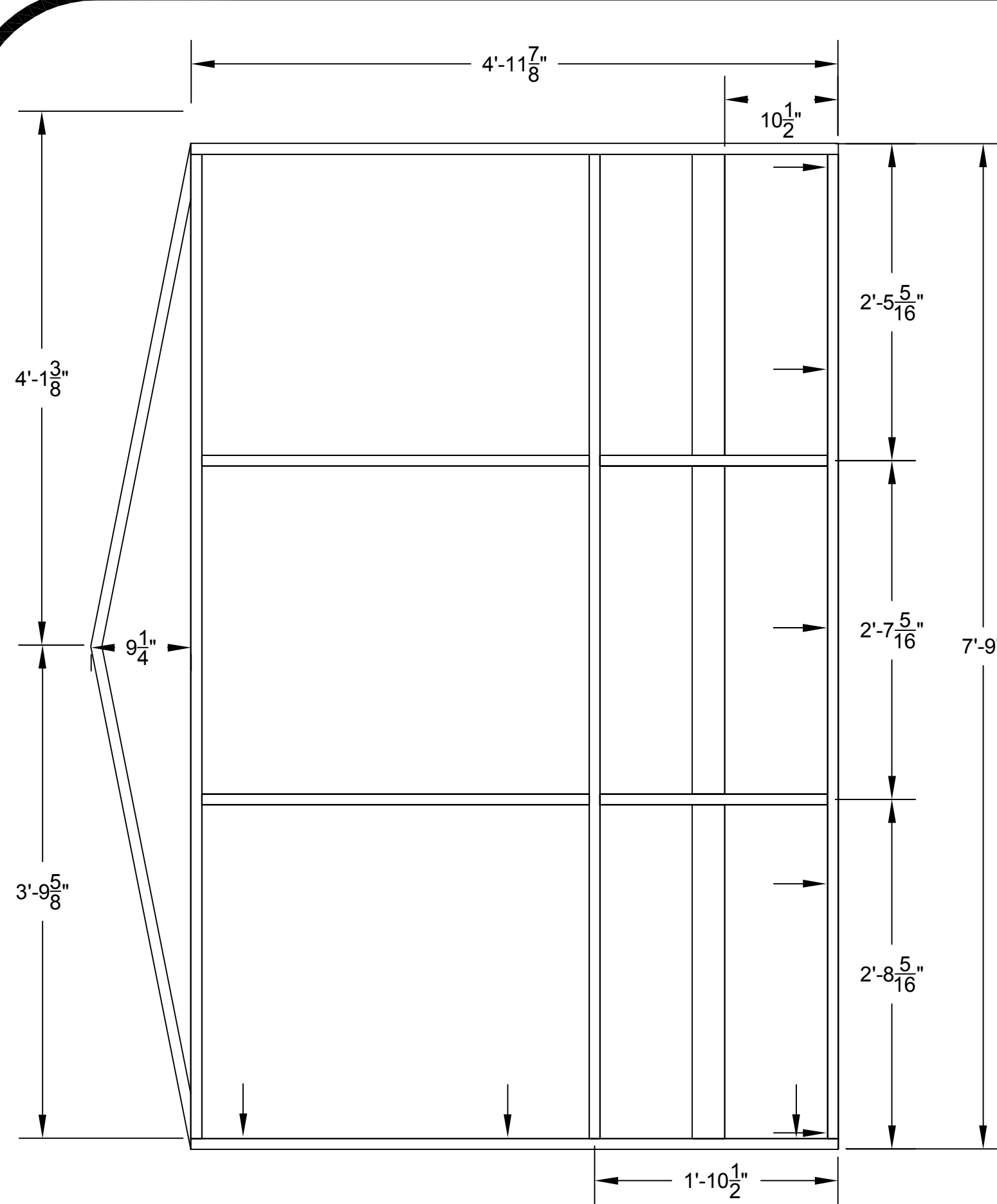

HOUSE WAGON FRAMING
PLATFORM A

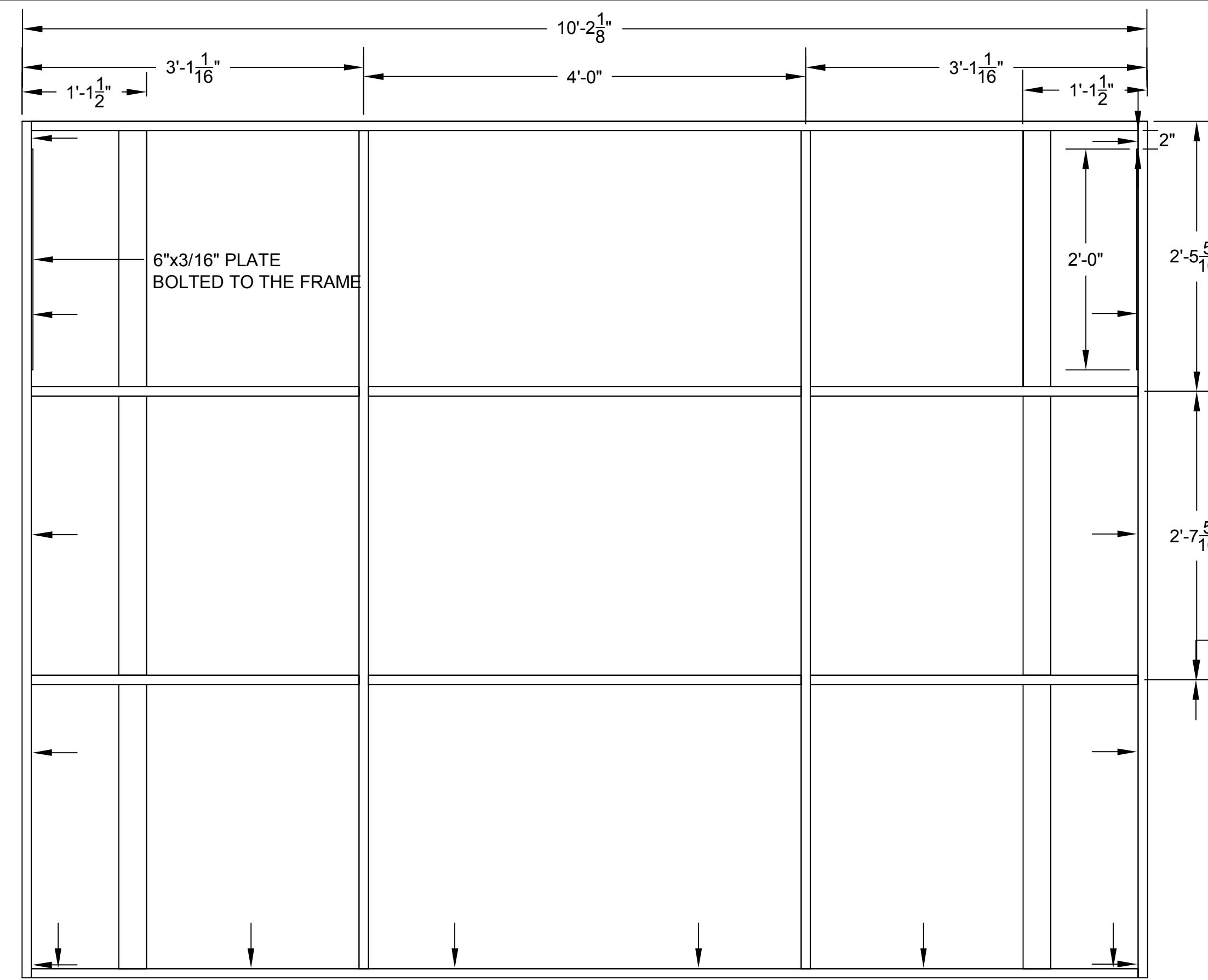

HOUSE WAGON FRAMING
PLATFORM C

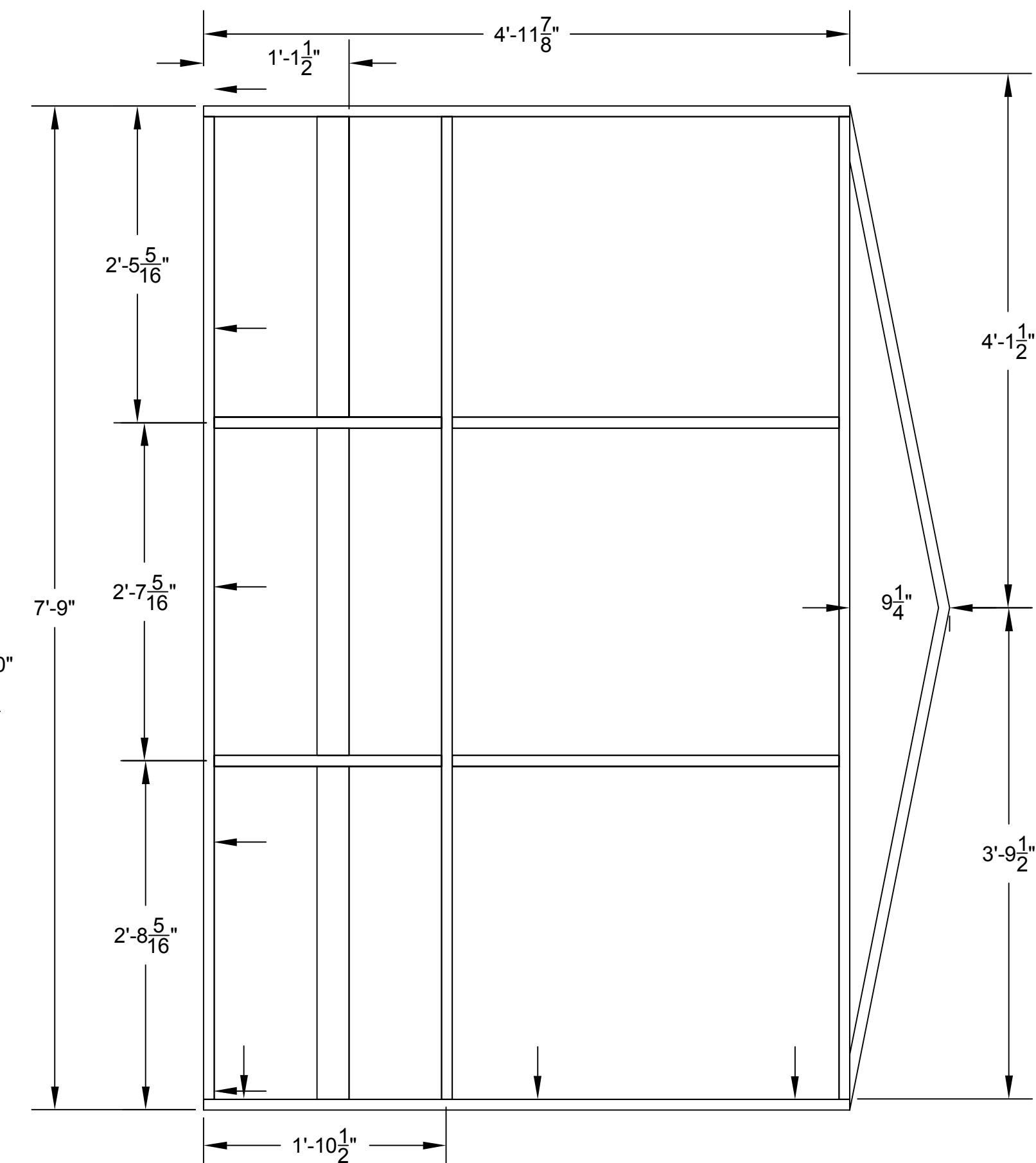

HOUSE WAGON FRAMING
PLATFORM E

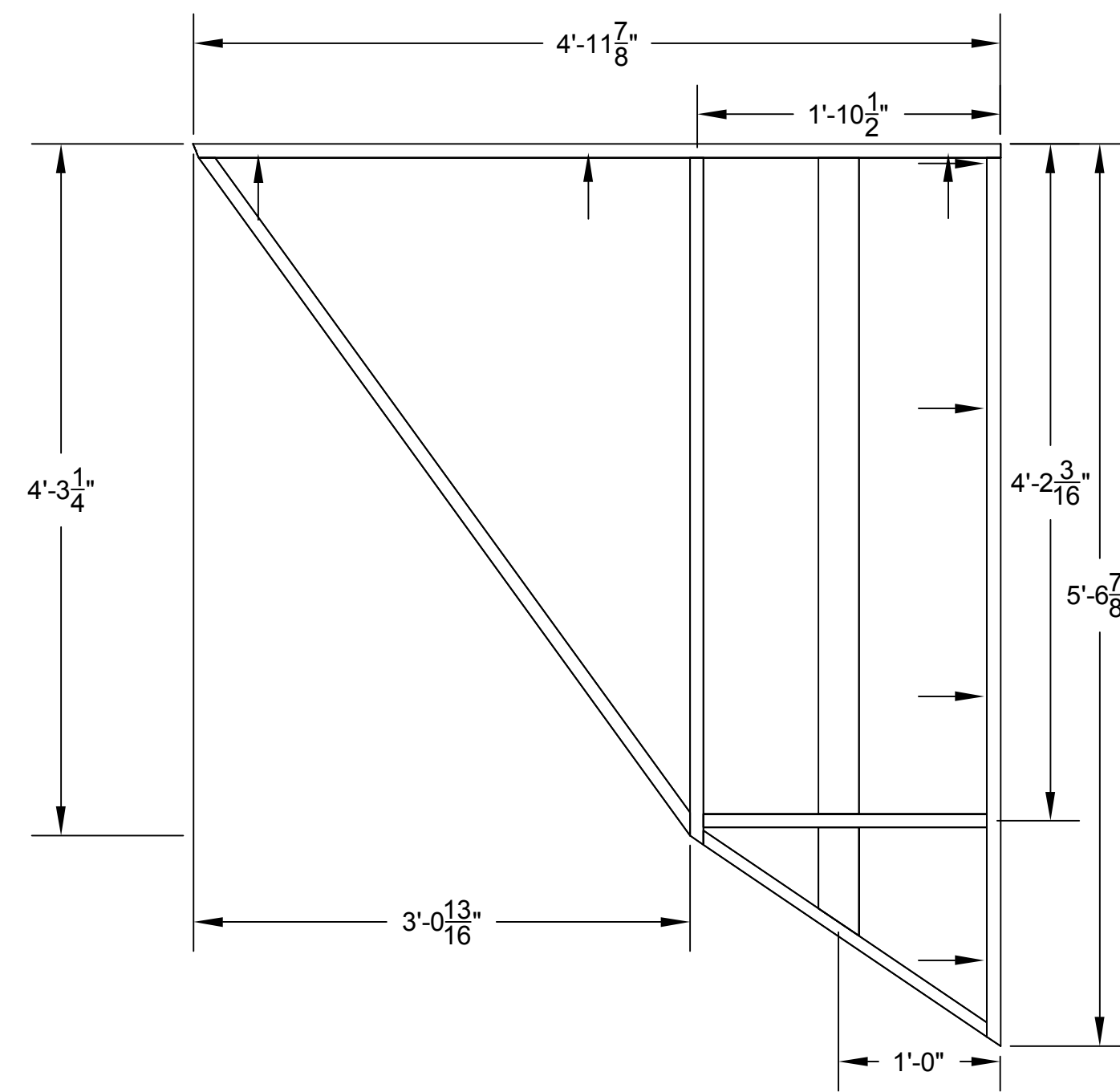

HOUSE WAGON FRAMING
PLATFORM B

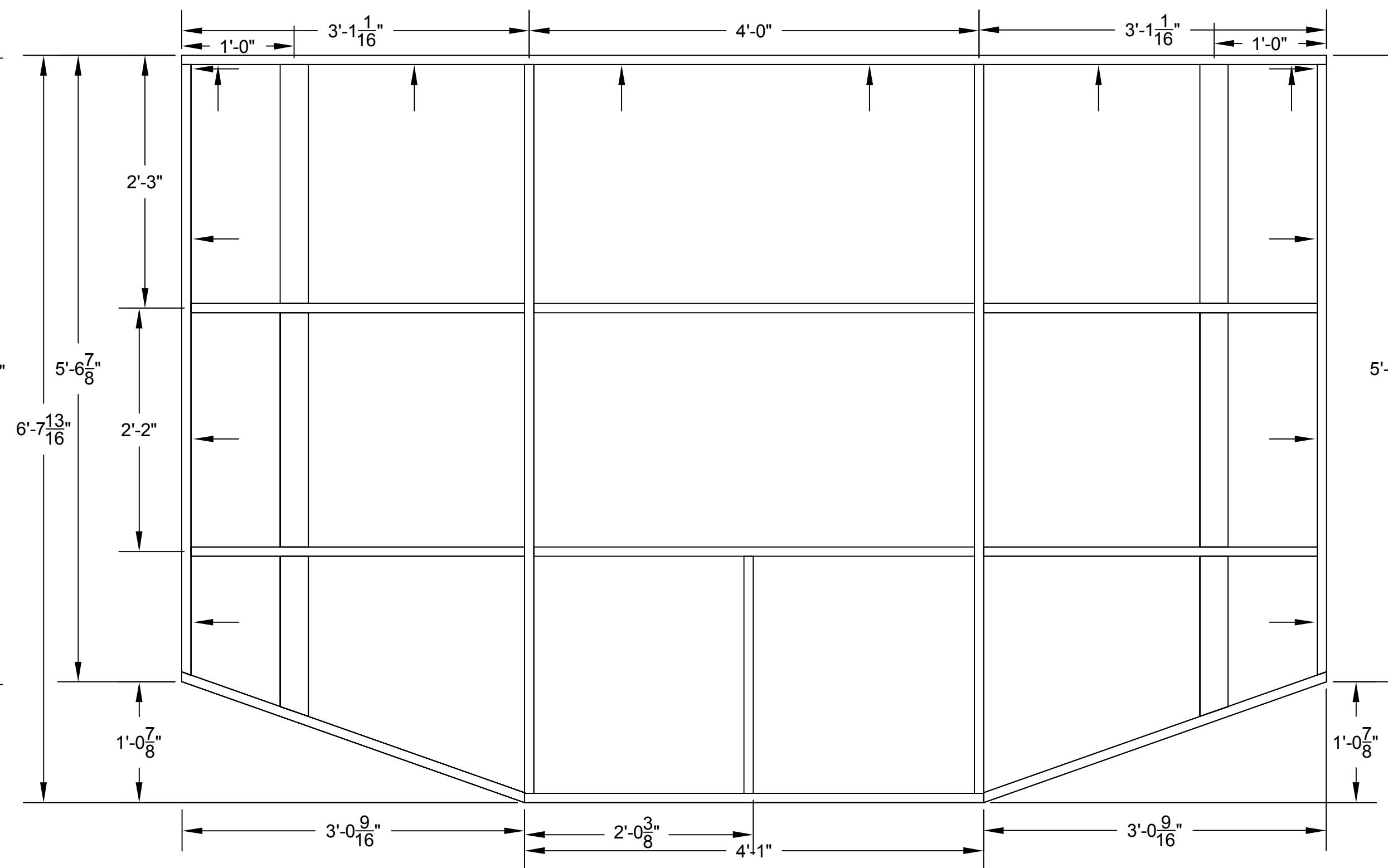

HOUSE WAGON FRAMING
PLATFORM D

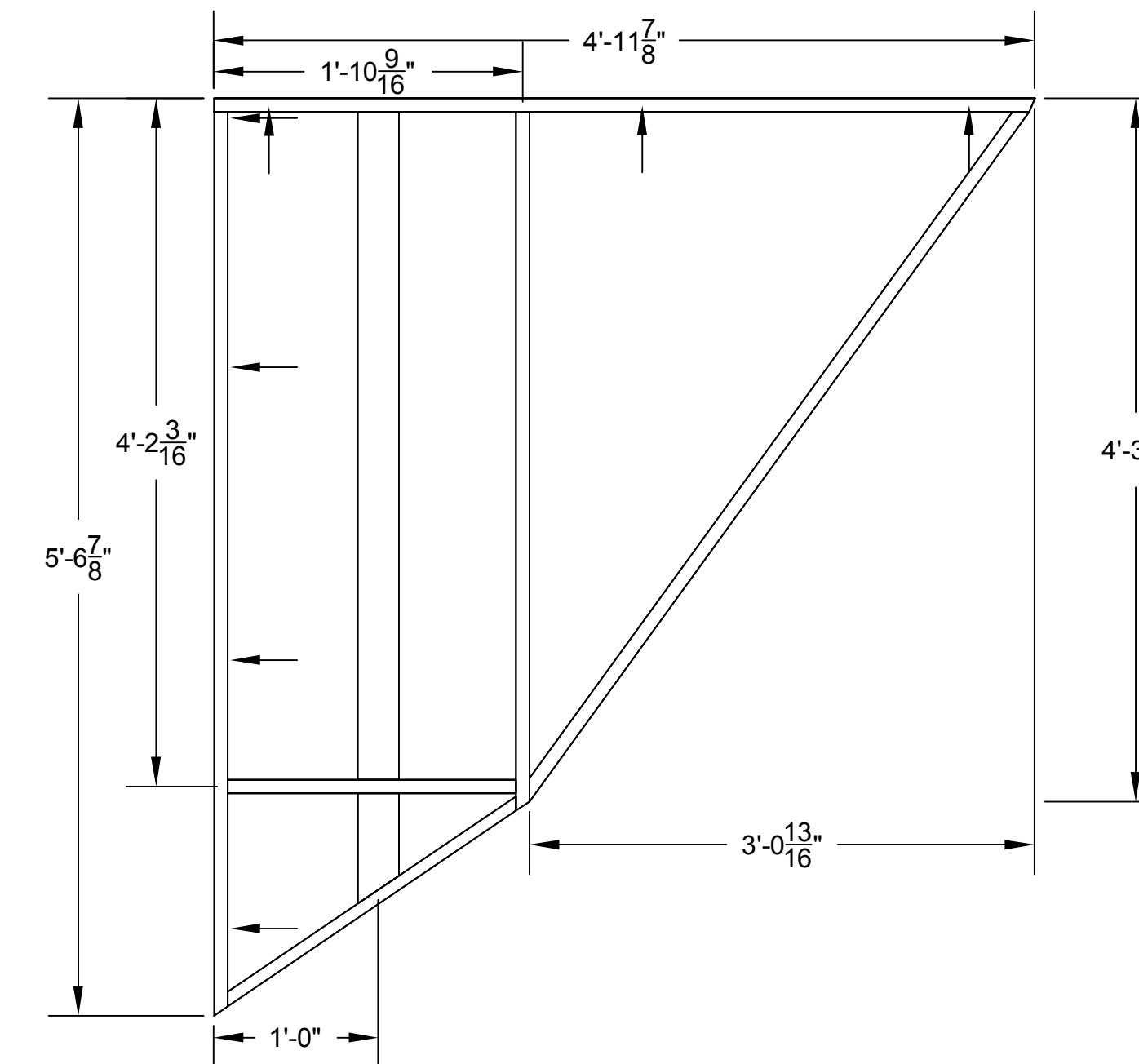

HOUSE WAGON FRAMING
PLATFORM F

ALL FRAMING 1X3
RECTANGULAR TUBING

PRE-DRILL FOR BOLT HOLES
BEFORE WELDING

→ REPRESENTS APPROX.
PLACEMENT OF BOLT HOLES
APPROX. EVERY 2'

USE 3/8" BOLTS

PREDRILL 2 HOLES FOR
EACH 6" PLATE
PLATE WILL BE BOLTED
THROUGH BOTH PLATFORMS

PLATE MOUNTED 1.5" FROM
THE TOP OF FRAMING

MATERIALS:
20 STICKS OF 1X3
4' OF 6"x3/16" PLATE

DIRECTOR	GAVIN CAMERON-WEBB
DESIGNER	RUSSELL METHENY
TD	CHRIS NOBLE
DRAWN BY	AMY MYERS



WHILE WE WERE BOWLING
HOUSE PLATFORM
FRAMING

STUDIO ARENA THEATRE
710 MAIN ST
BUFFALO, NY 14202

Project	HOUSE PLATFORM	Sheet	9
Date	1.20.04		
Scale	1"=1'-0"		

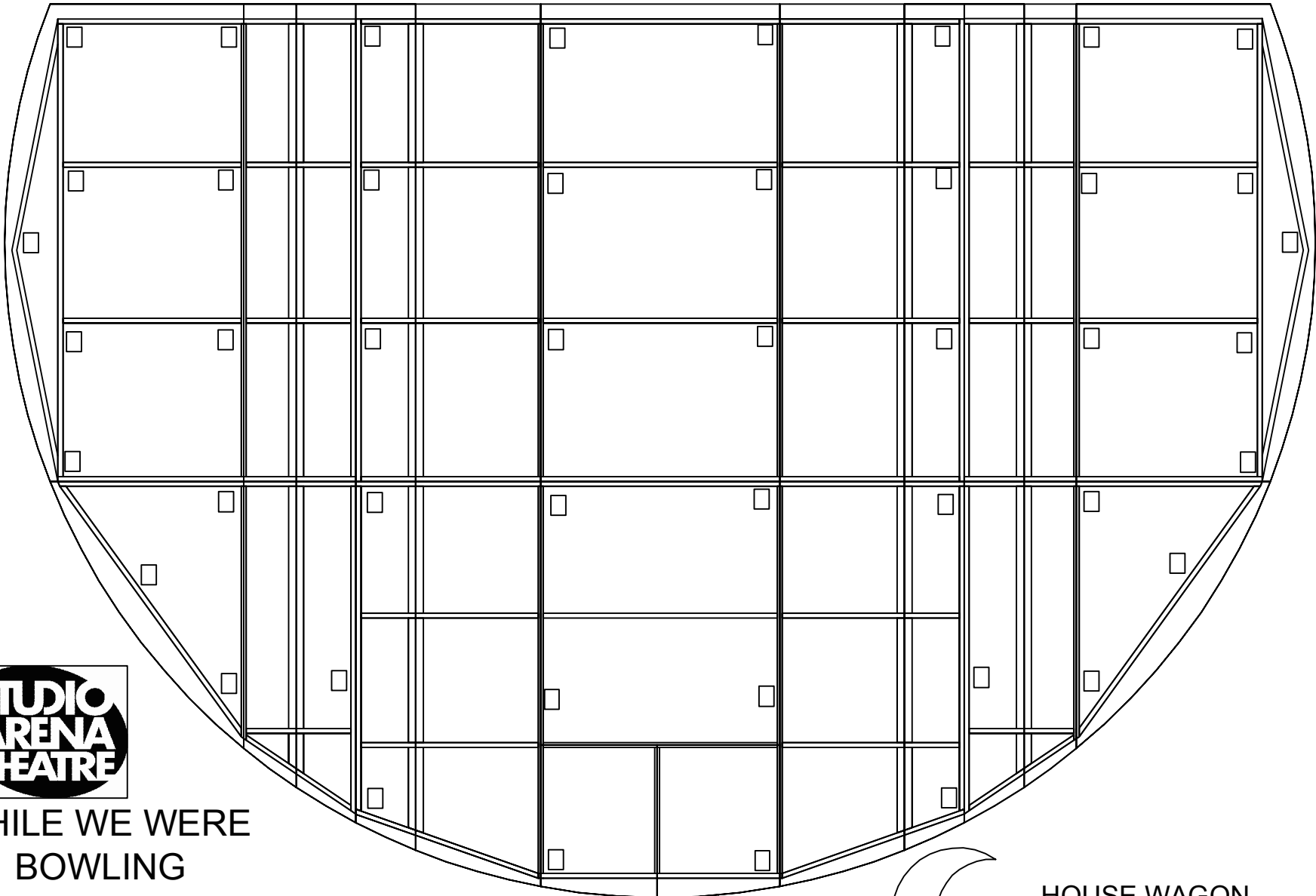

WHILE WE WERE
BOWLING
SHEET **10**

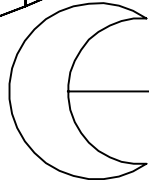

HOUSE WAGON
CASTER LAYOUT

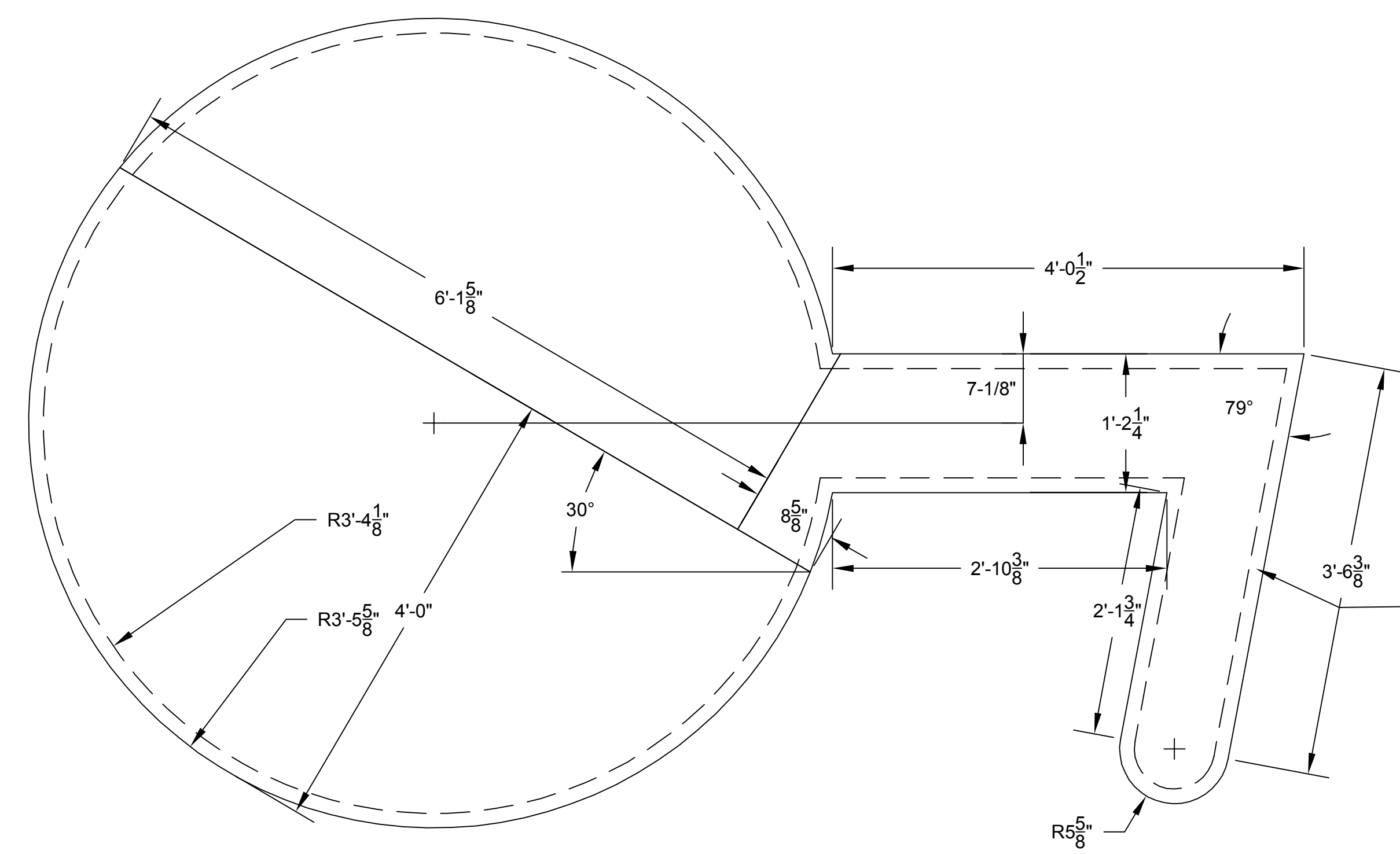

ALLEY WAGONS
PLY AND PLY RIB LAYOUT

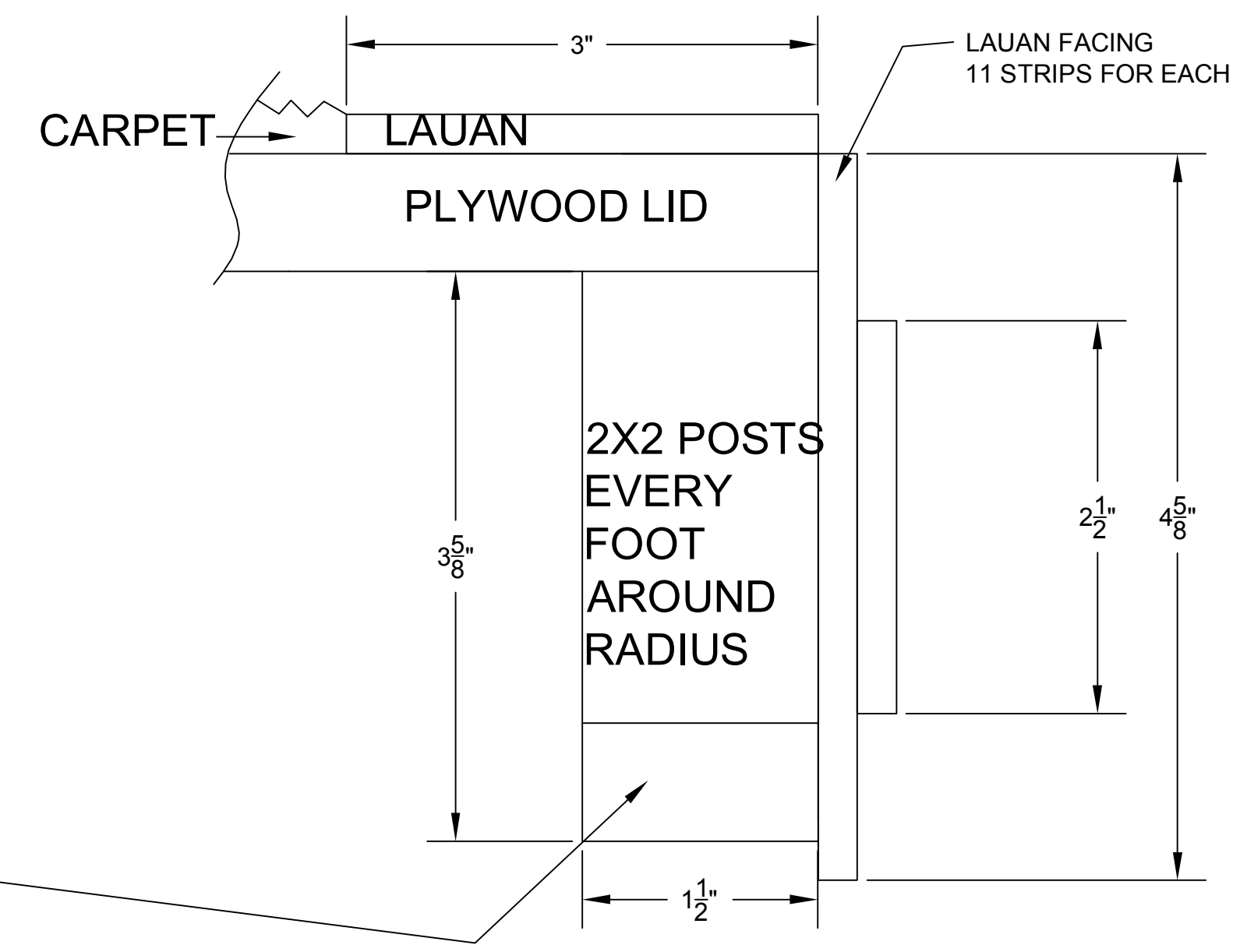

ALLEY WAGON FACING DETAIL
FULL SCALE

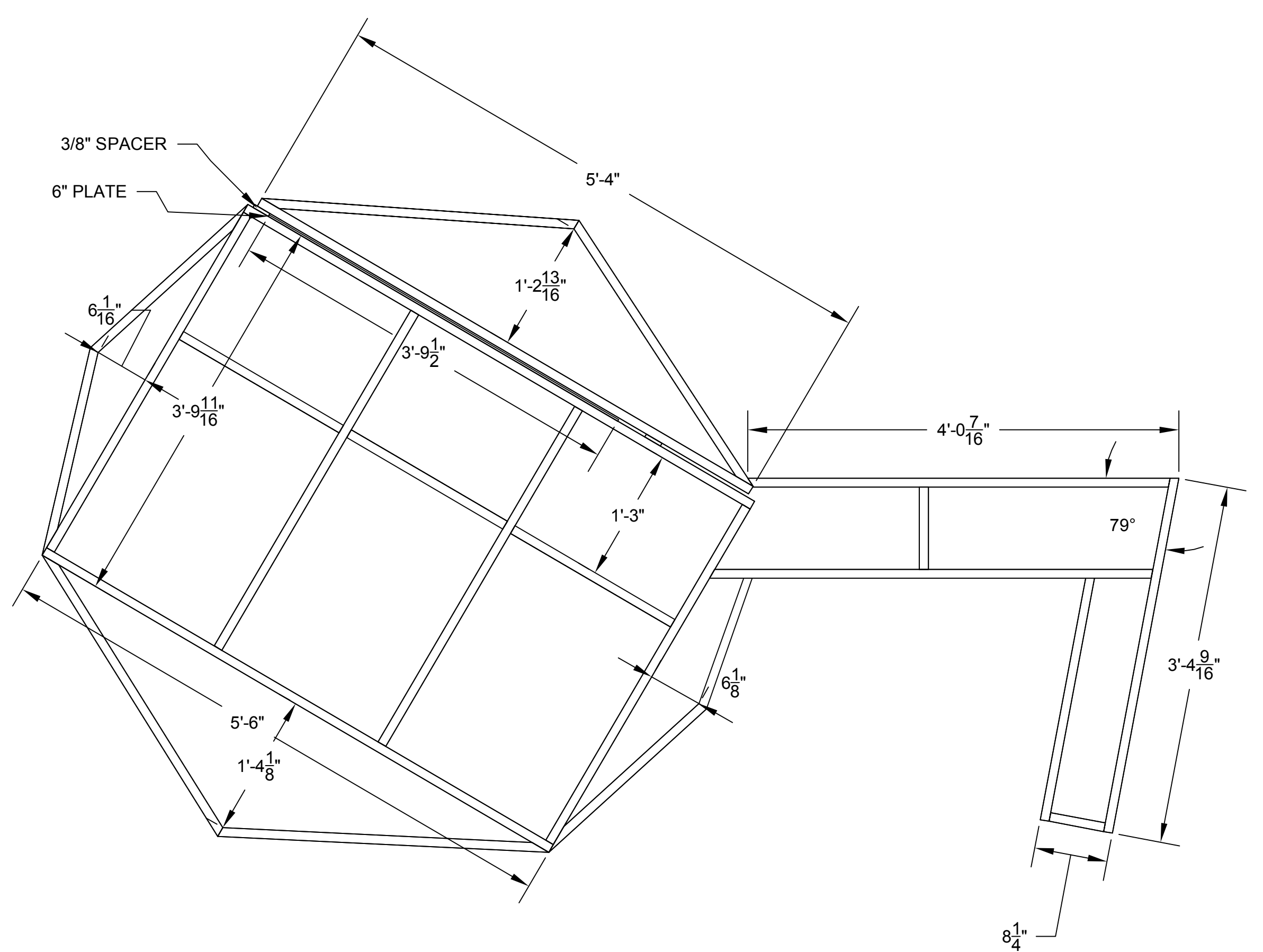

ALLEY WAGONS
1X3 FRAMING

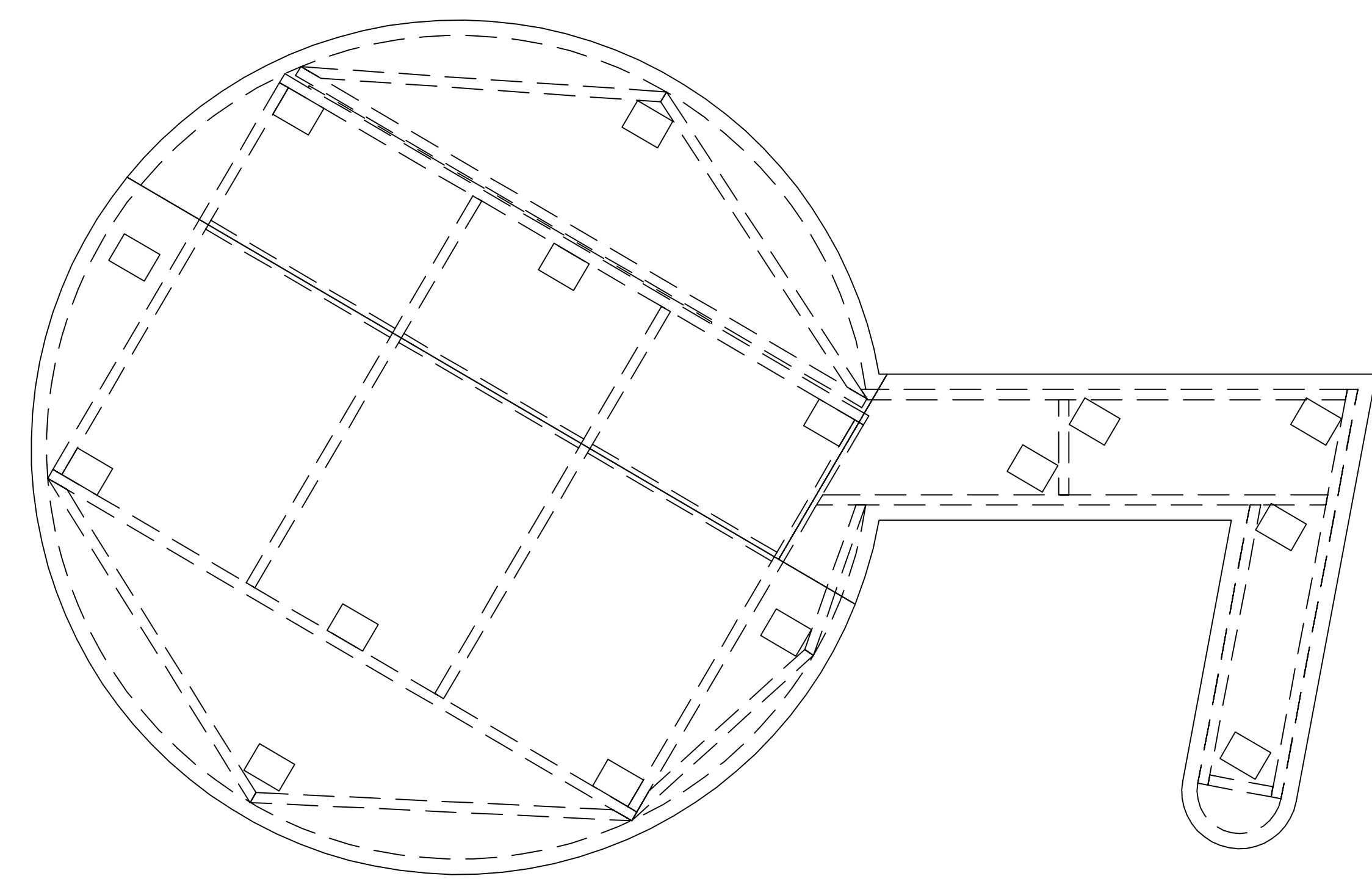

ALLEY WAGONS
CASTER PLACEMENT

ALL VIEWS SHOWN ARE
TOP VIEWS OF SR
PLATFORM

SL IS REVERSE AND
REPEAT

FACING SHOULD BE CUT,
BUT NOT APPLIED

MATERIALS FOR EACH:
3 18MM LAUAN
5 1X3

2 SHTS LAUAN
1 SHT 18MM LAUAN
1 2X4

DIRECTOR	GAVIN CAMERON-WEBB
DESIGNER	RUSSELL METHENY
TD	CHRIS NOBLE
DRAWN BY	AMY MYERS



WHILE WE WERE
BOWLING
ALLEY WAGONS

STUDIO ARENA THEATRE
710 MAIN ST
BUFFALO, NY 14202

Project	ALLEY WAGONS	Sheet	11
Date	1.22.04		
Scale	1"=1'-0"		

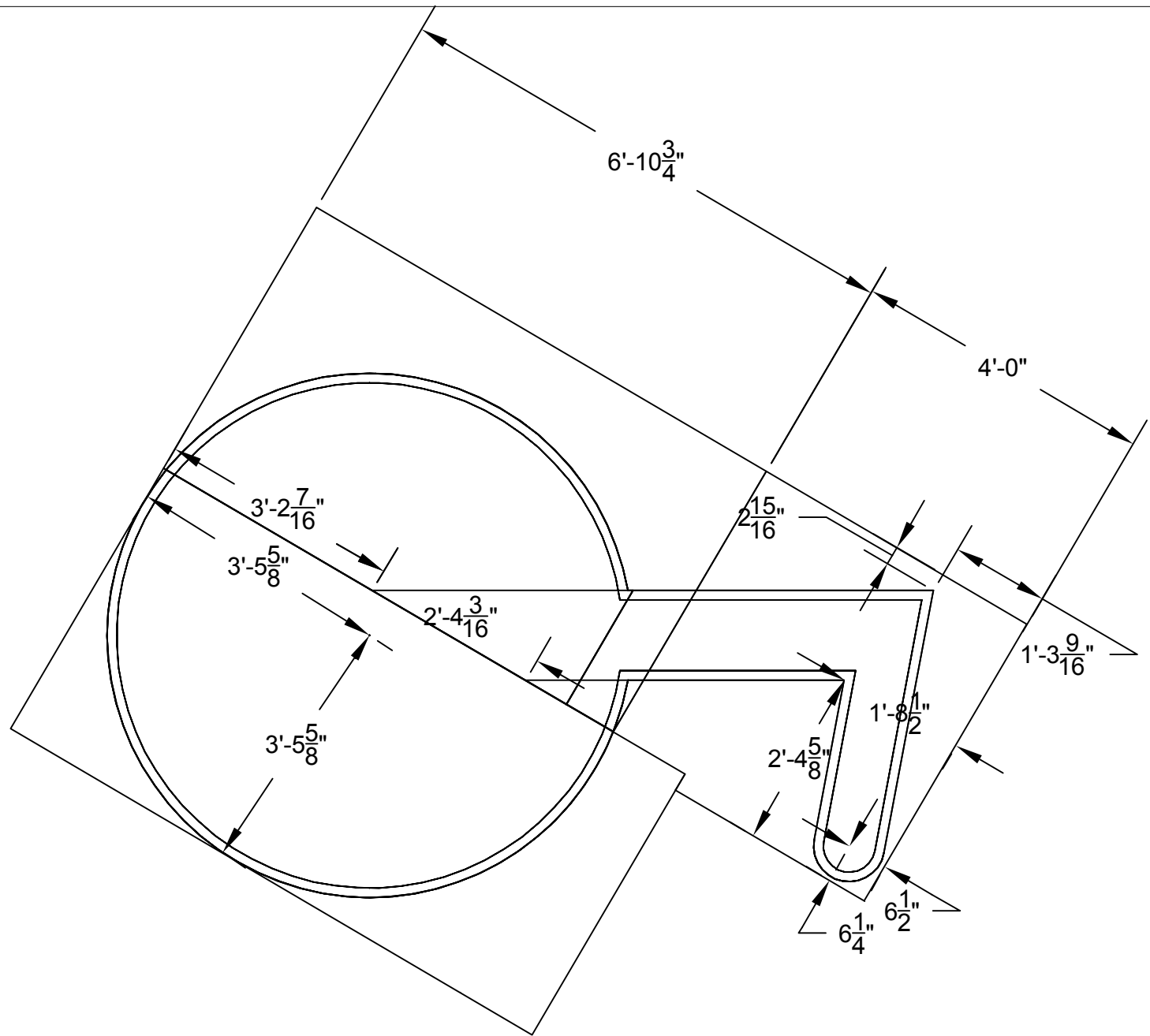

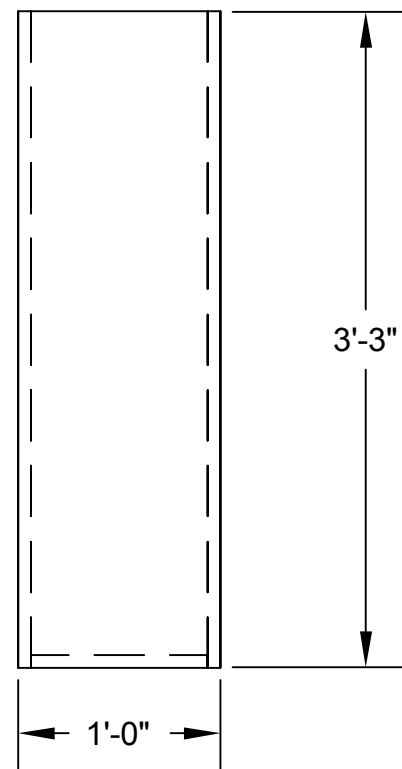
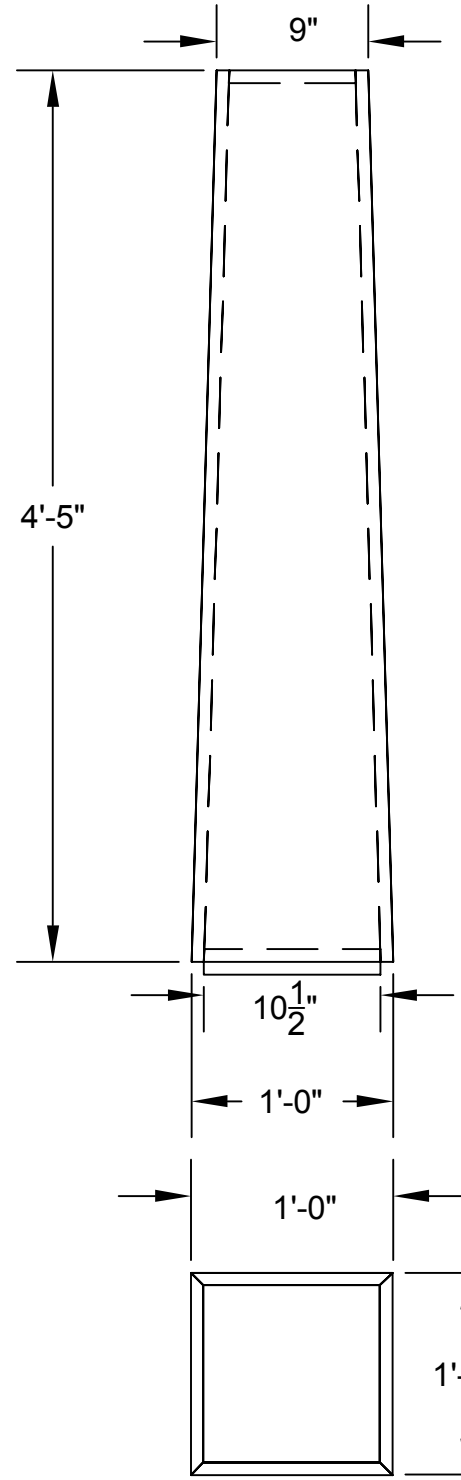
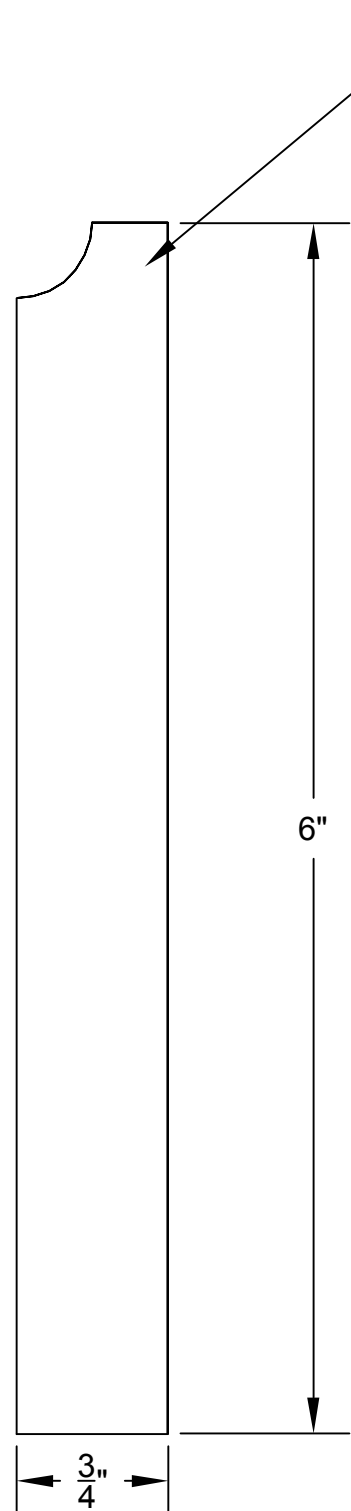
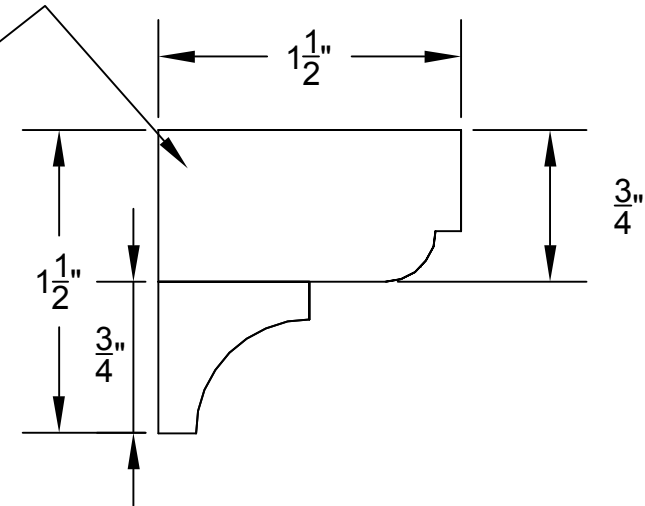
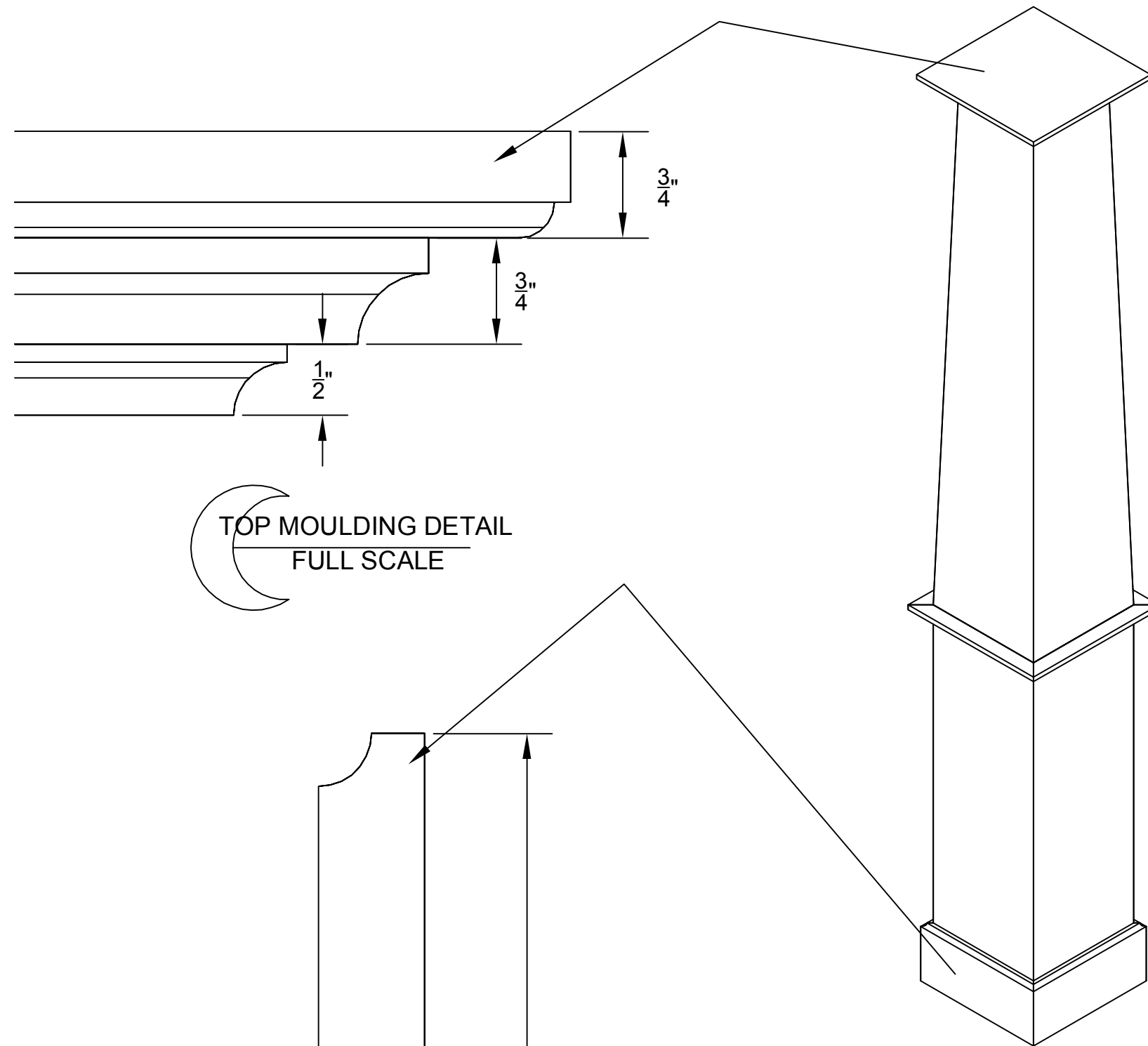
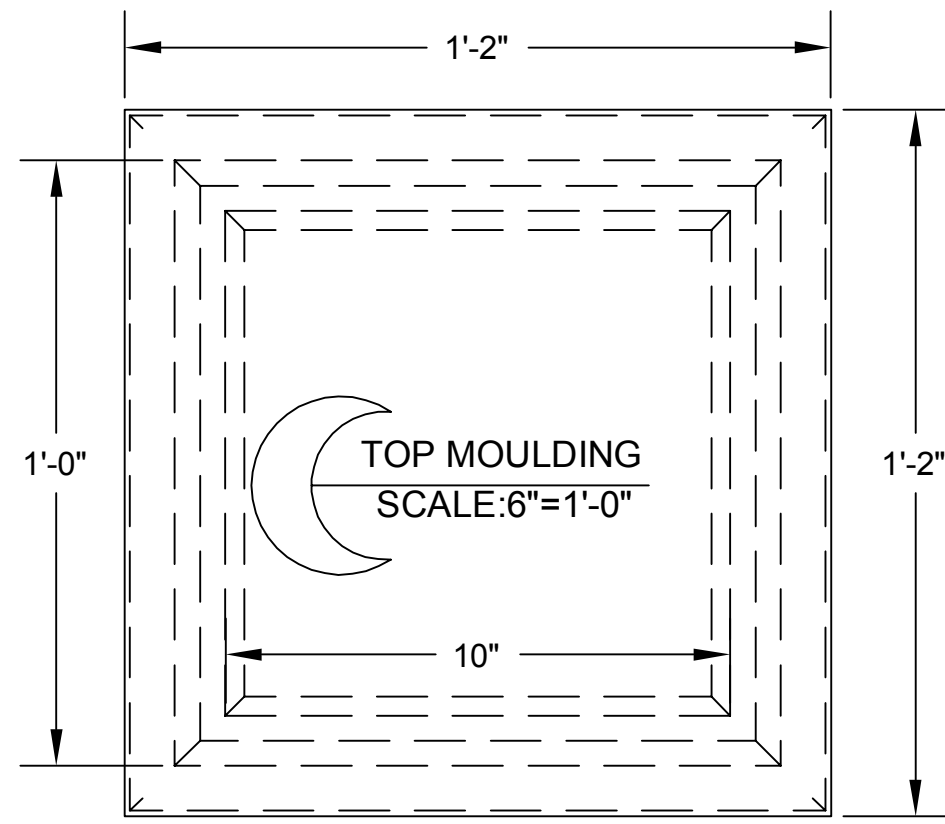
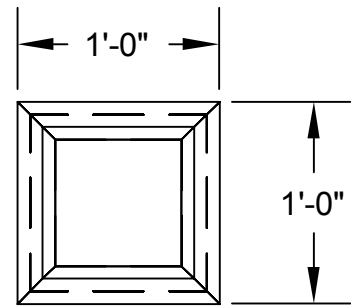

COLUMN TOP
SCALE: 1"=1'-0"

TOP MOULDING DETAIL
FULL SCALE

MIDDLE MOULDING DETAIL
FULL SCALE

ASSEMBLED VIEW
SCALE: 1"=1'-0"

BASE MOULDING DETAIL
FULL SCALE

ALL CORNERS ARE
MITERED AT 45°

TOP MOULDING IS THREE
SEPERATE PIECES

DIRECTOR	GAVIN CAMERON-WEBB
DESIGNER	RUSSELL METHENY
TD	CHRIS NOBLE
DRAWN BY	AMY MYERS



WHILE WE WERE
BOWLING
COLUMNS

STUDIO ARENA THEATRE
710 MAIN ST
BUFFALO, NY 14202

Project	COLUMNS
Date	1.22.04
Scale	1"=1'-0"

Sheet
12

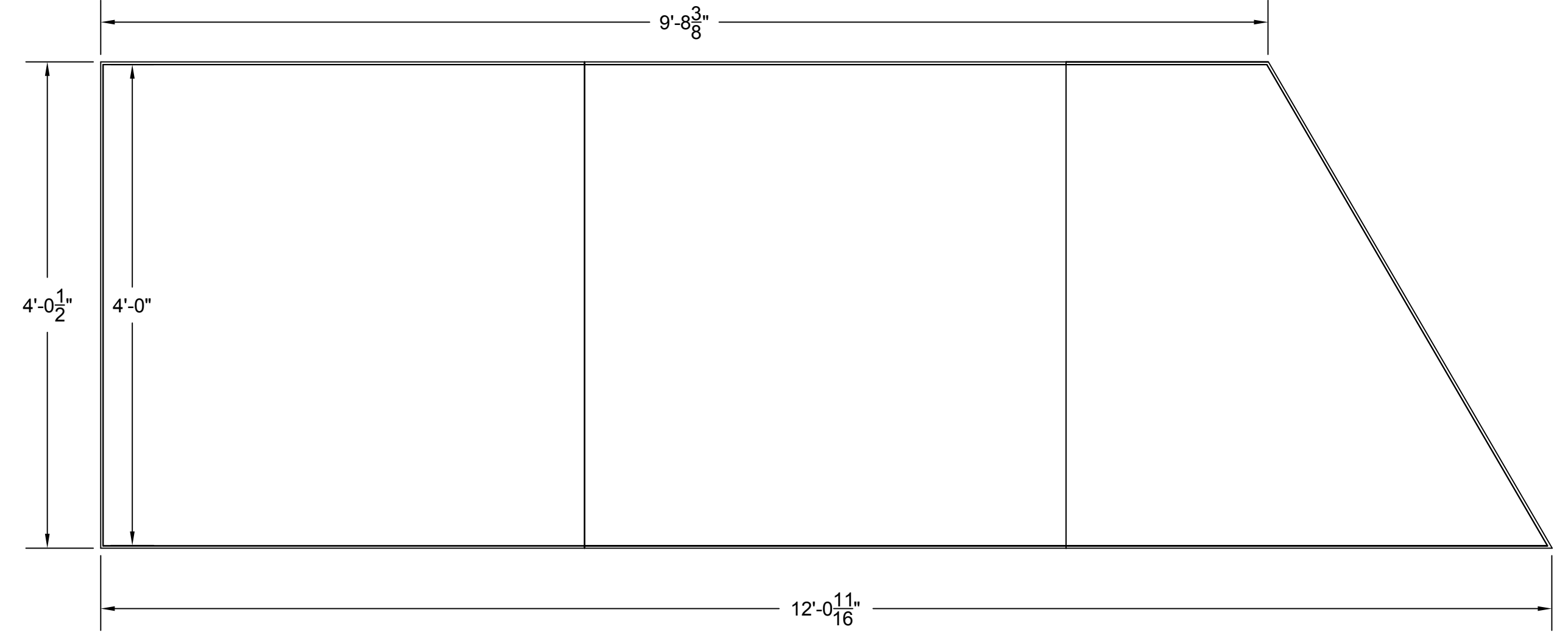
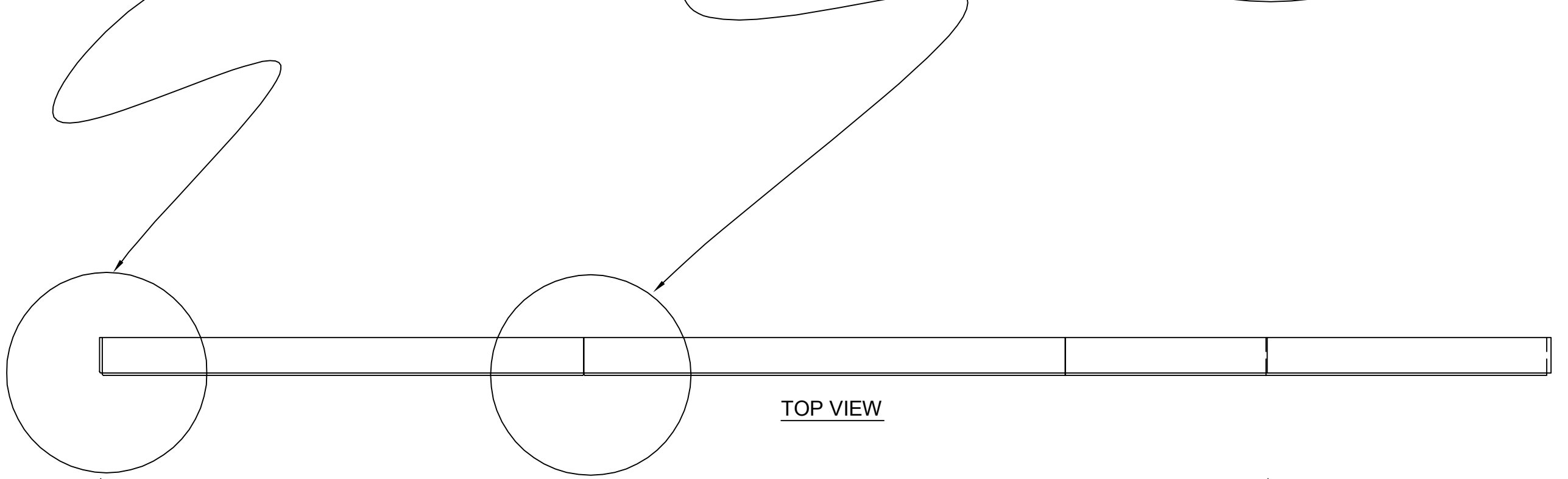
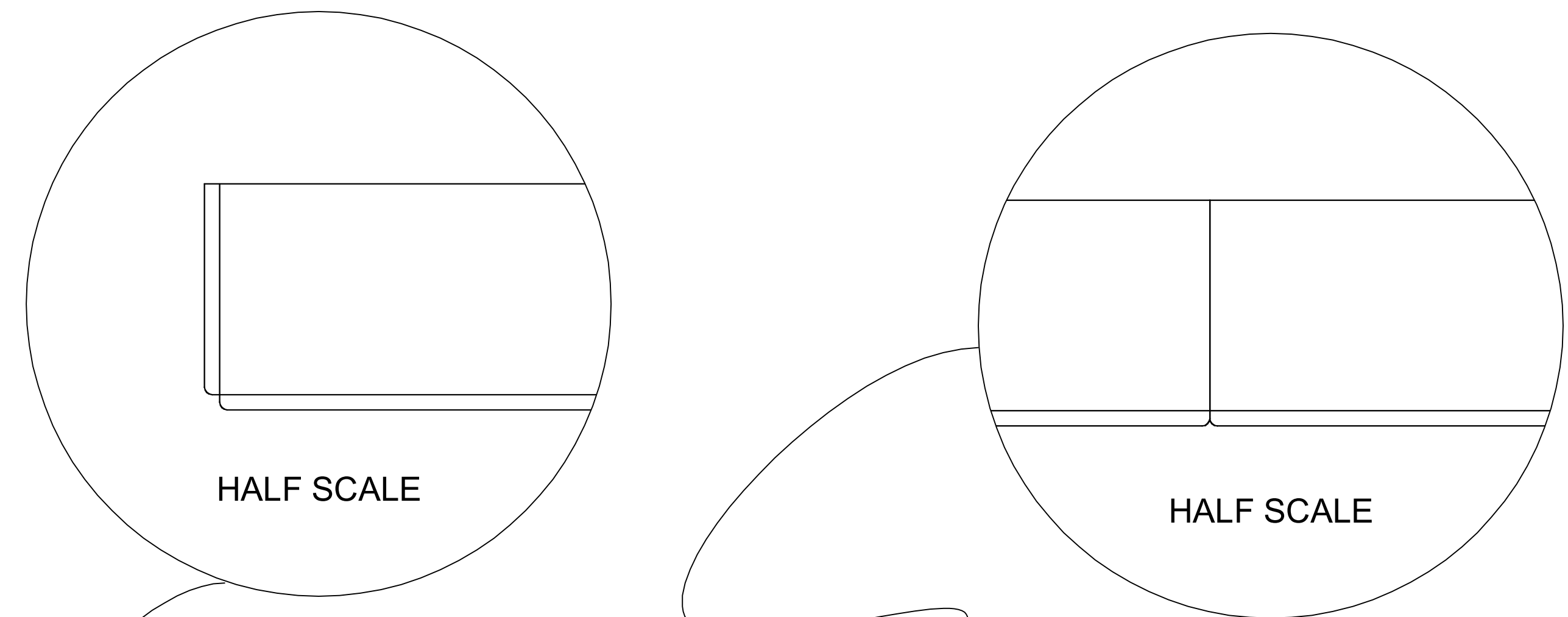

FRONT VIEW
SIGN SIDE FLAT
LAUAN

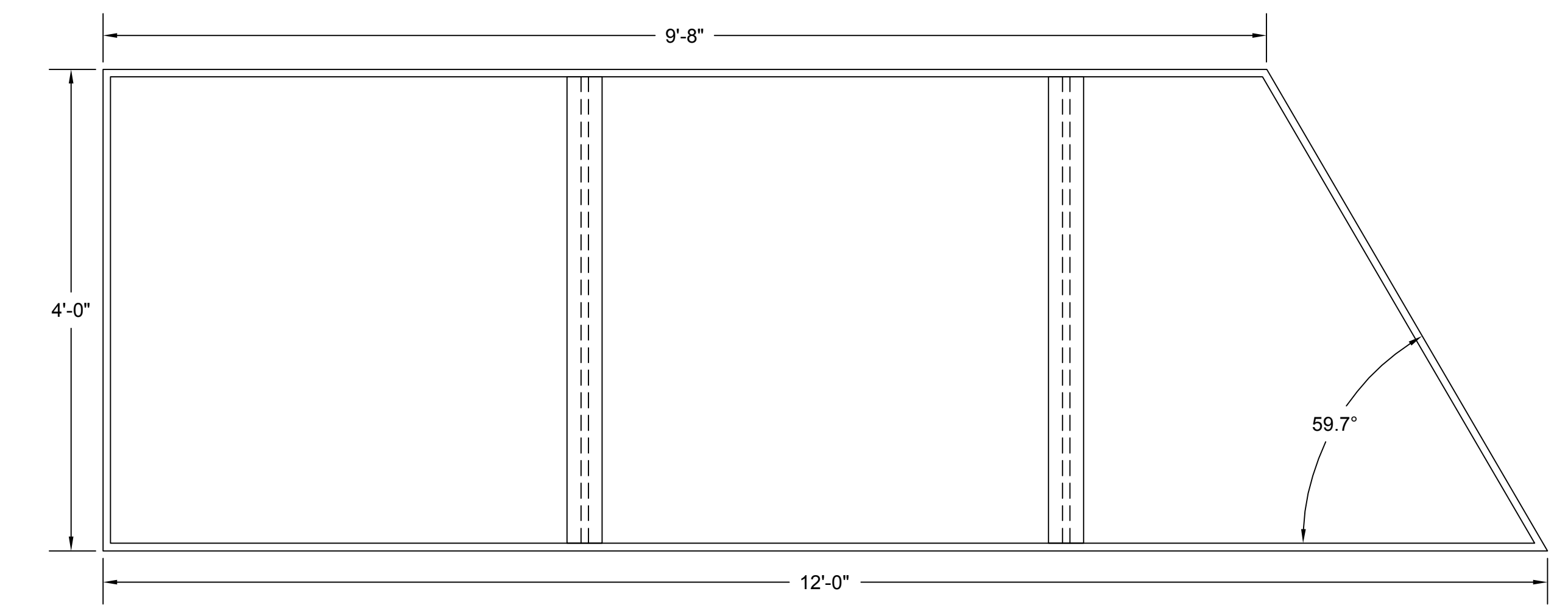
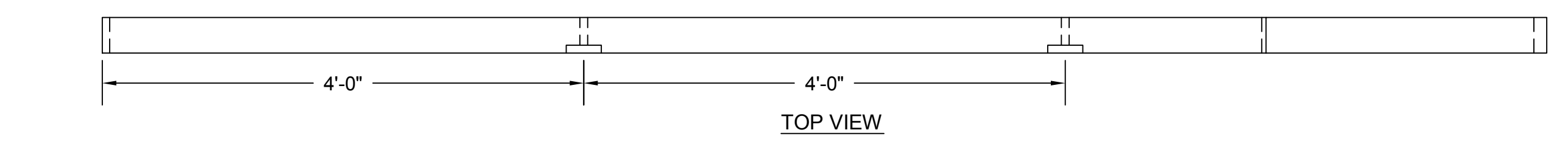

FRONT VIEW
SIGN SIDE FLAT
FRAMING

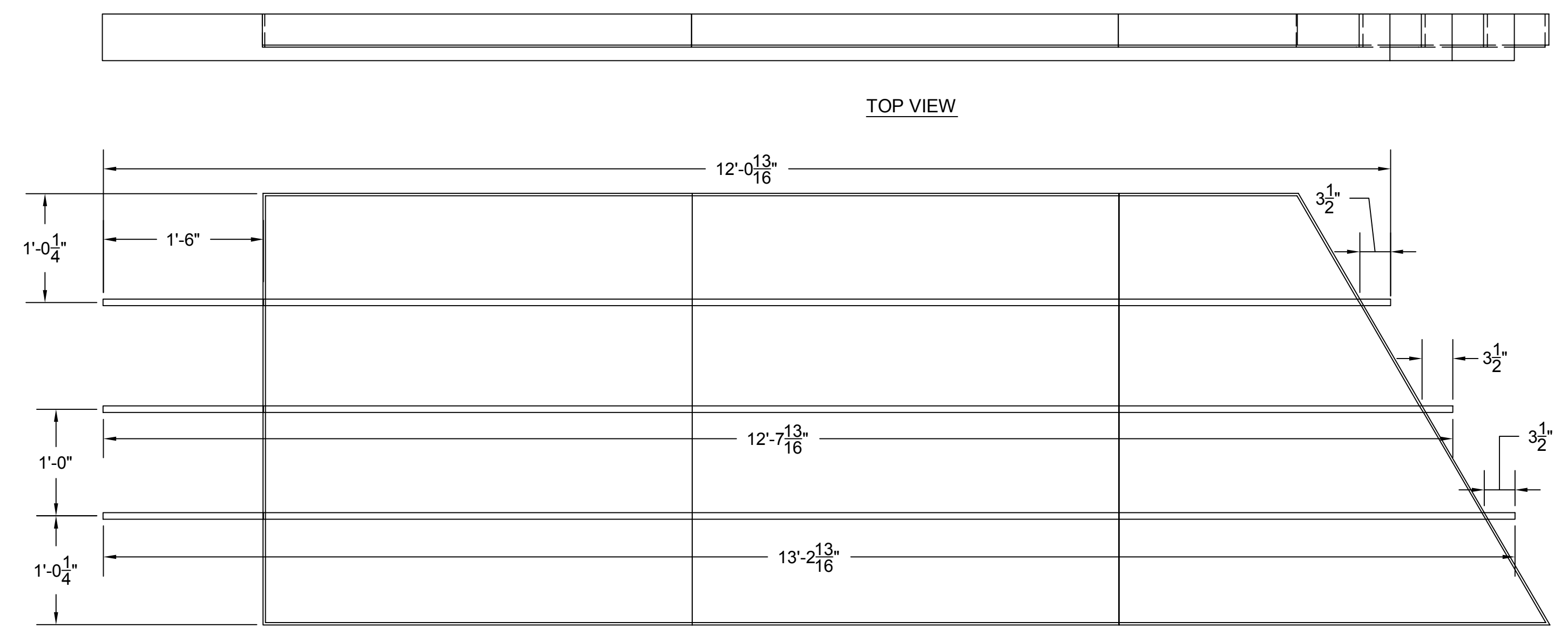

TOP VIEW

FRONT VIEW

SIGN SIDE FLAT
TRIM

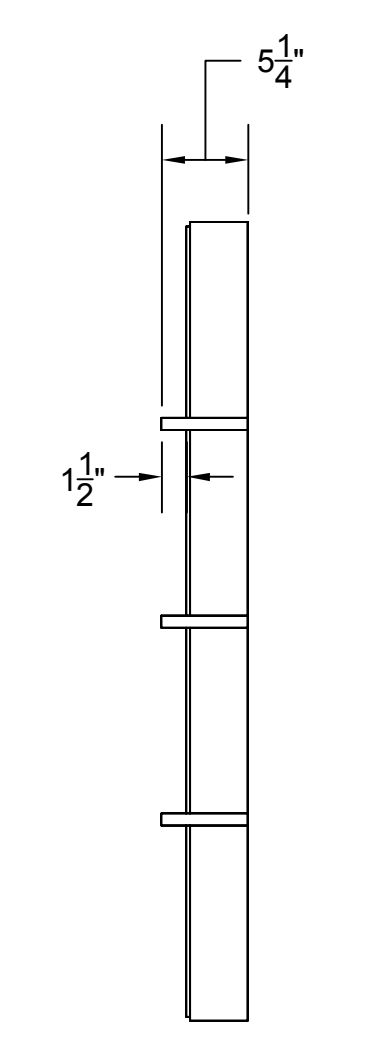

SIDE VIEW

SIGN SIDE FLAT (SR) R&R FOR SL

General Notes	
SKIN WITH $\frac{1}{4}$ " LAUAN GRAIN RUNS HORIZONTAL TRIM TO BE MADE FROM 1x6 (PREFERABLY STRAIGHT...)	
DIRECTOR	GAVIN CAMERON-WEBB
DESIGNER	RUSSELL METHENY
TO	CHRIS NOBLE
DRAWN BY	NOBLE



BOWLING
VOLKER SIGN
SIDE PANELS
STUDIO ARENA THEATRE
710 MAIN ST
BUFFALO, NY 14202

Project	VOLKER SIGN SIDE PANELS	Sheet	13
Date	1.21.04		
Scale	1"=1'-0"		

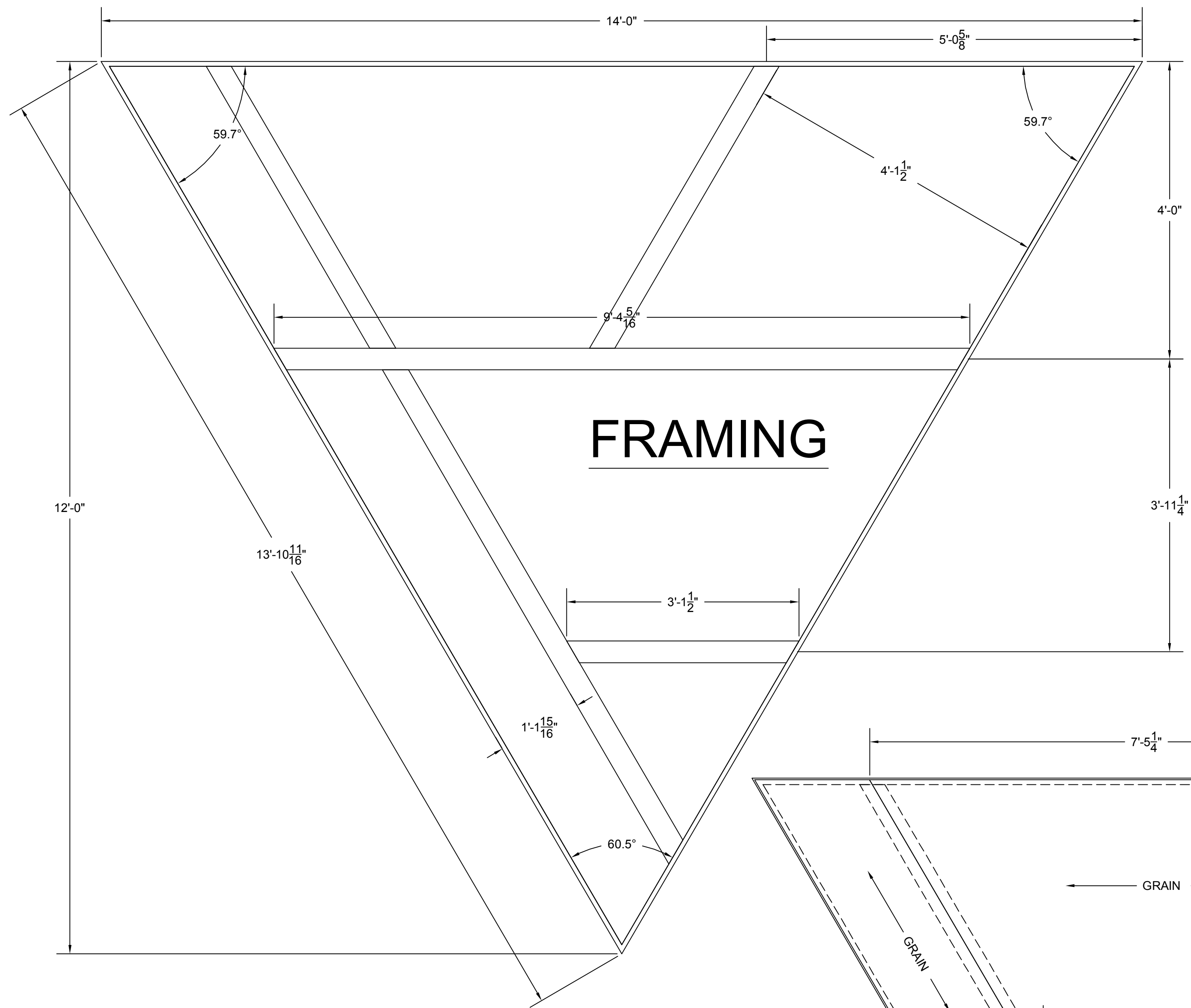

FRAMING

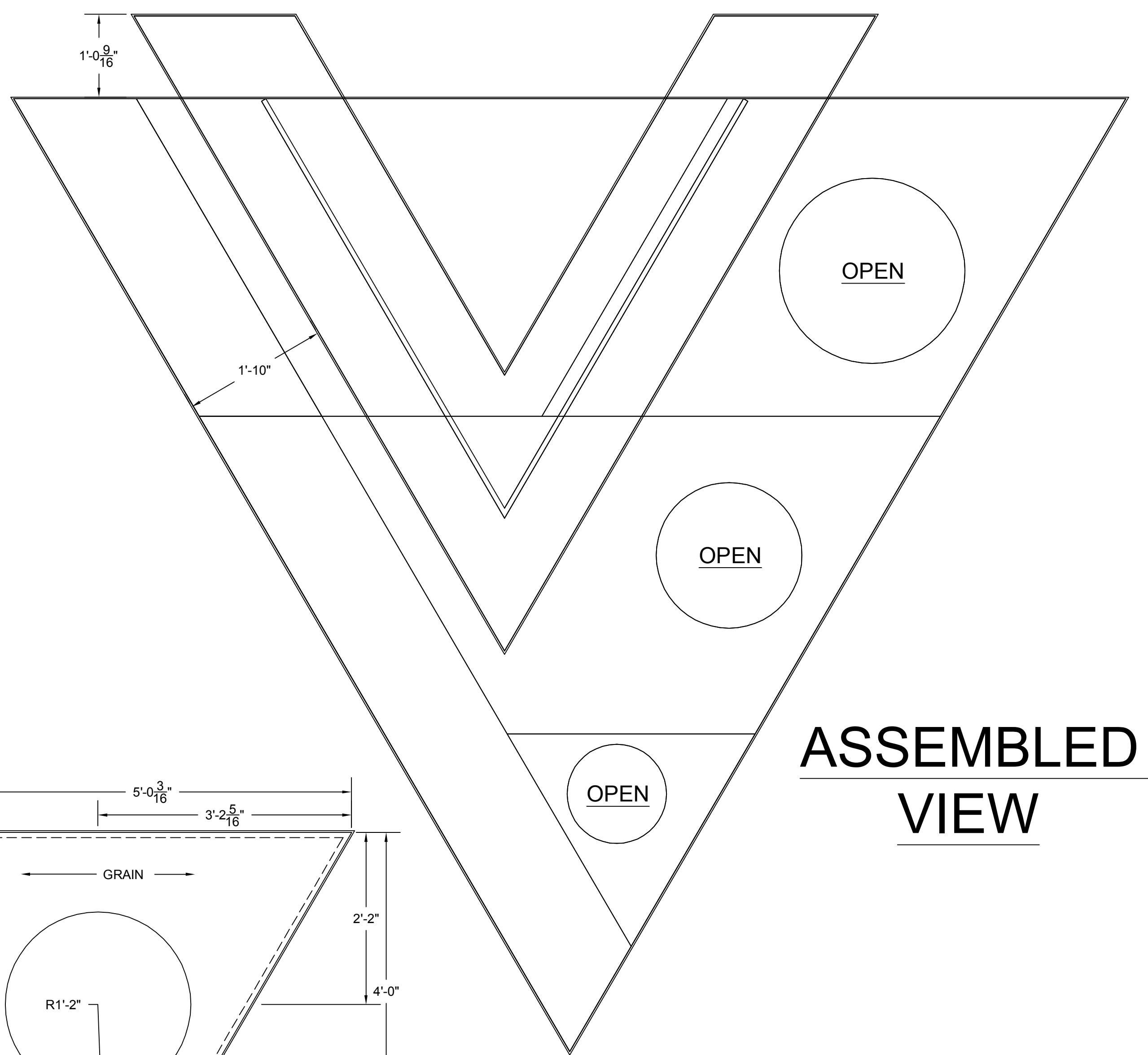

ASSEMBLED VIEW

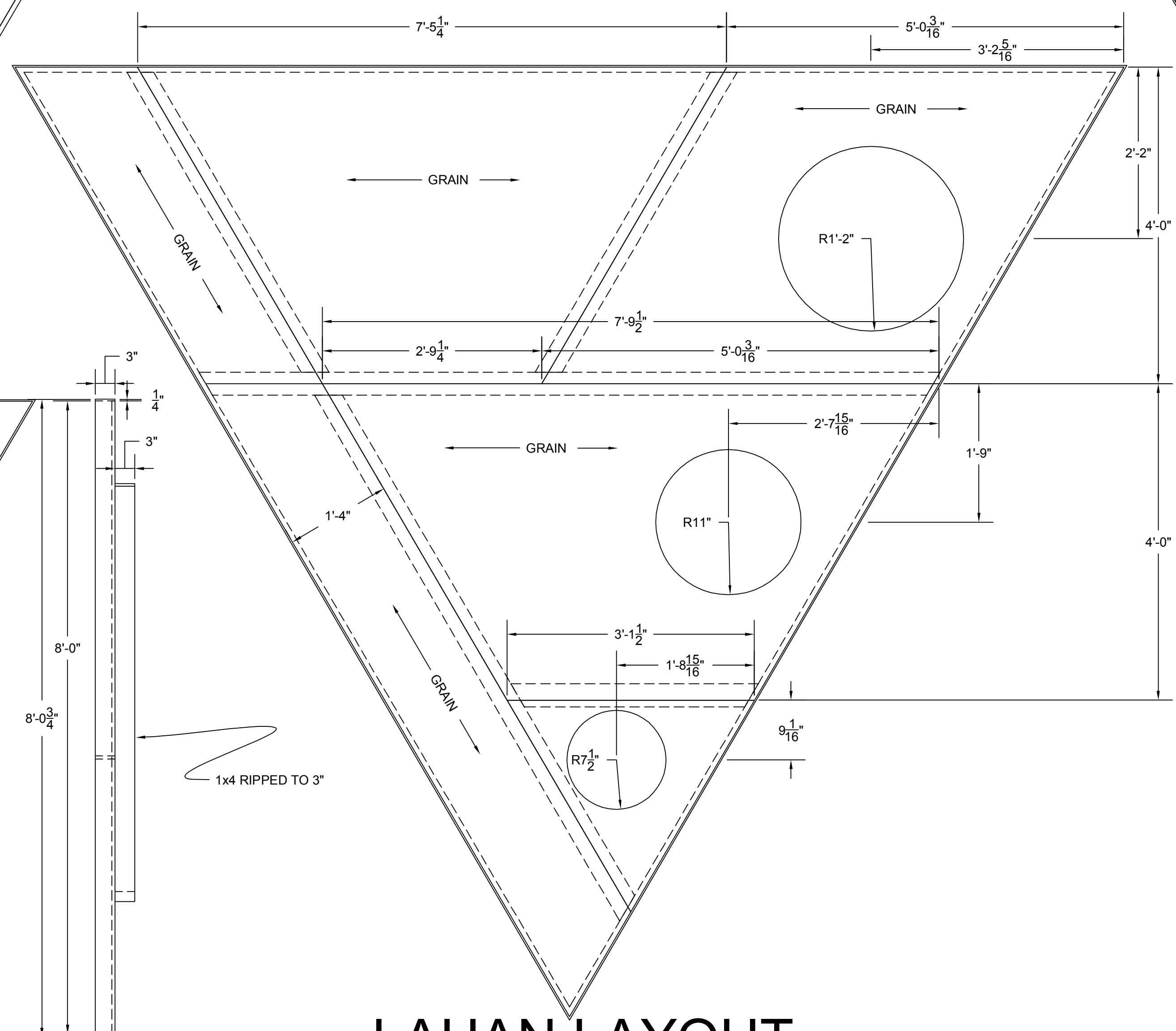

LAUAN LAYOUT

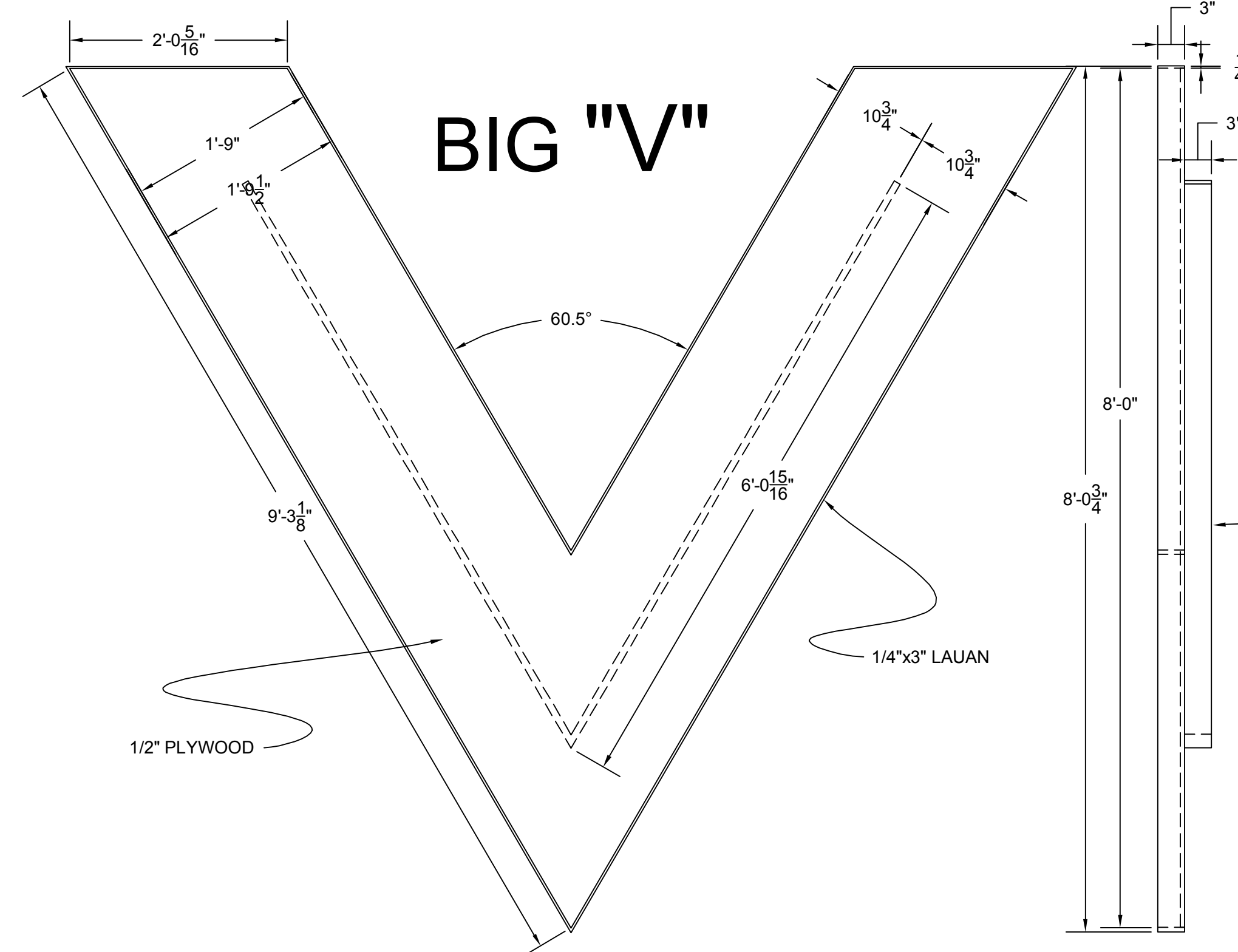

BIG "V"

LAUAN SEAMS TO BE SAME AS SIDE PANELS

ALSO-LAUAN FACING ON ALL SIDES

General Notes

- SKIN WITH 1/4" LAUAN
- NOTE GRAIN DIRECTION
- FRAME WITH 1x4

DESIGNER	GAVIN CAMERON-WEBB
DRAWN	RUSSELL METHENY
BY	CHRIS NOBLE
DATE	NOBLE

BOWLING VOLKER SIGN
STUDIO ARENA THEATRE
710 MAIN ST
BUFFALO, NY 14202

Project	VOLKER SIGN	Sheet	14
Date	1.21.04		
Scale	1"=1'-0"		

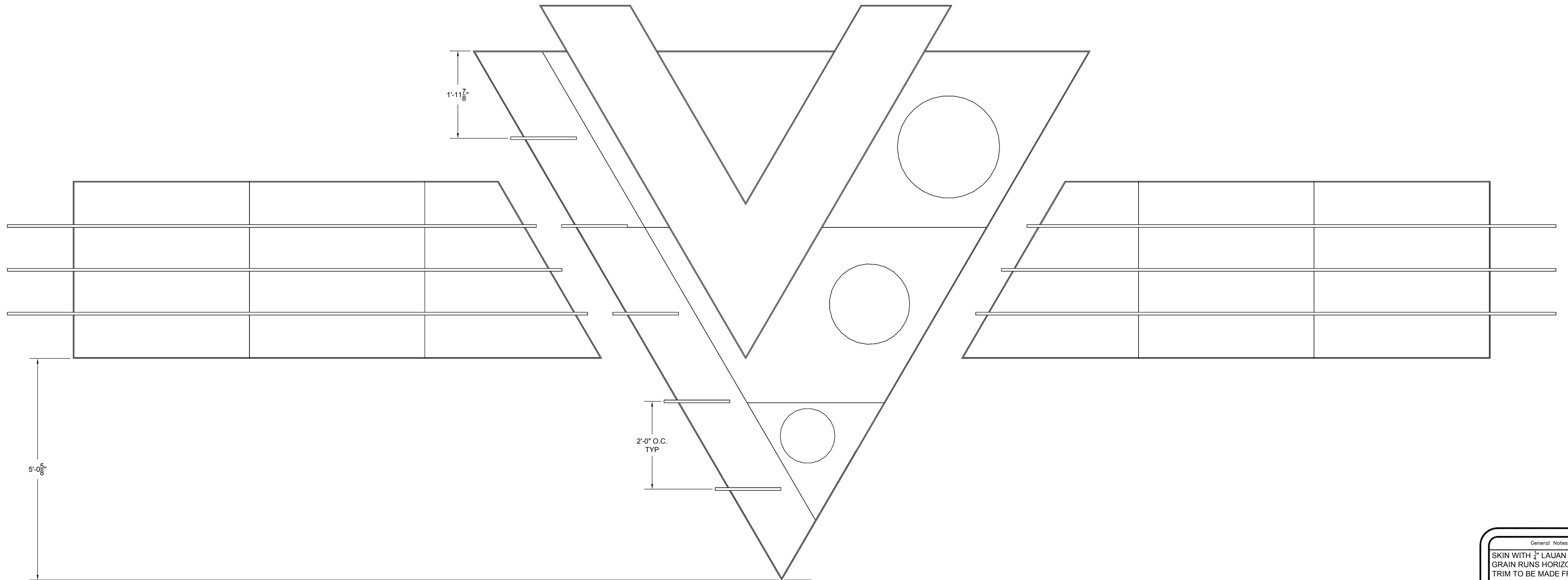

HANGS 3'-0" OFF DECK

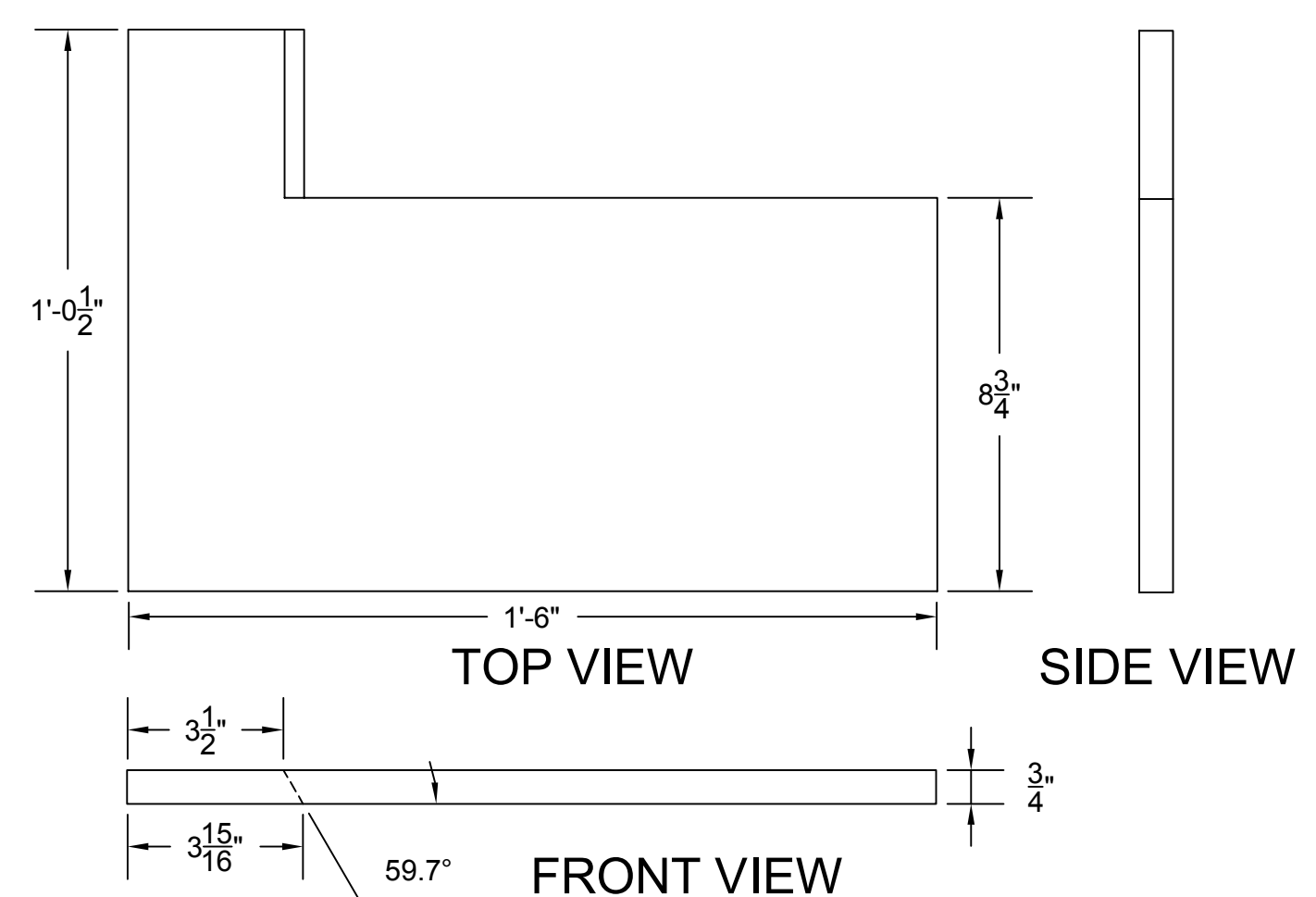

SHELVES

SHOWN IN RED

SCALE 3"=1'-0"

CUT FROM 3/4 PLY, FILL SIDES

General Notes	
SKIN WITH 1/4" LAUAN GRAIN RUNS HORIZONTAL TRIM TO BE MADE FROM 1x6 (PREFERABLY STRAIGHT...)	
DIRECTOR	GAVIN CAMERON-WEBB
DESIGNER	RUSSELL METHENY
TD	CHRIS NOBLE
DRAWN BY	NOBLE



BOWLING
VOLKER SIGN
LAYOUT
STUDIO ARENA THEATRE
710 MAIN ST
BUFFALO, NY 14202

Project	VOLKER SIGN LAYOUT	Sheet	15
Date	1.21.04		
Scale	1"=1'-0"		

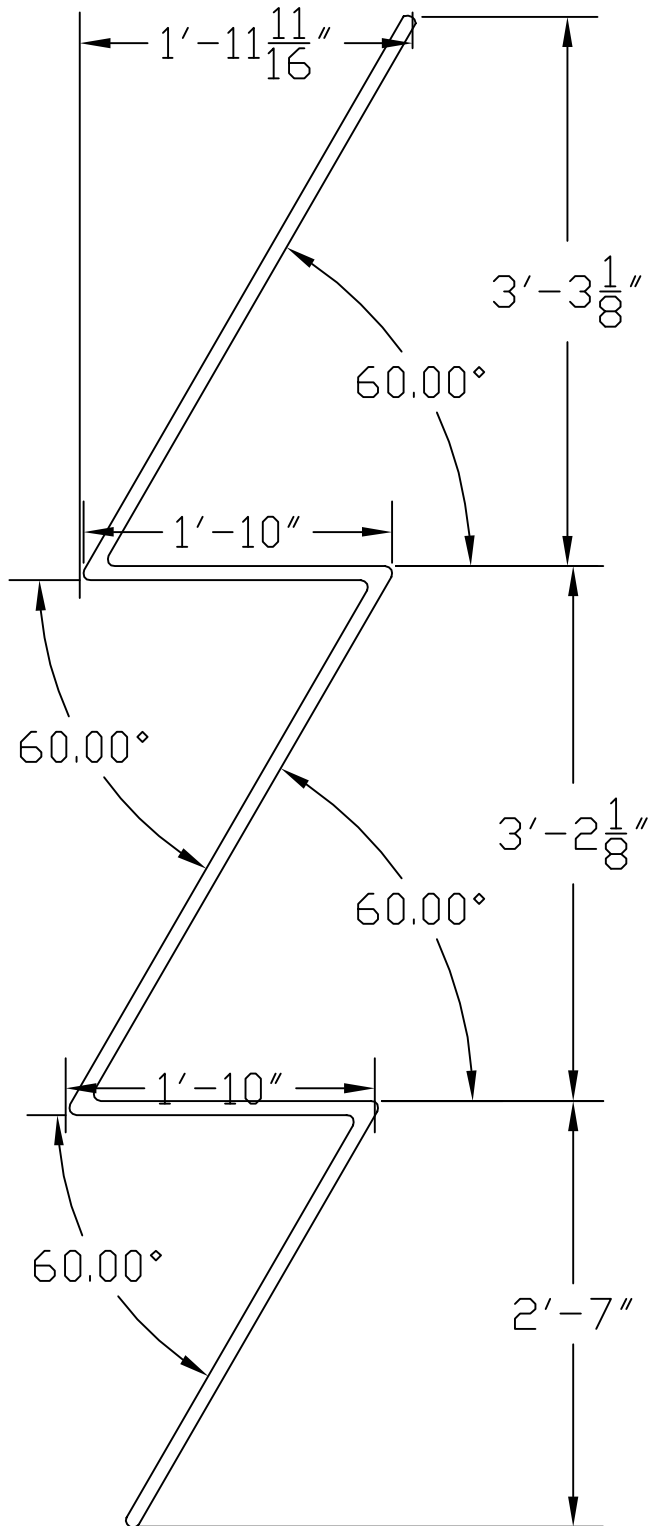

Straight pieces

- 1@
- 8' 6"
- 8'
- 7' 6"
- 7'
- 6' 8-1/2"
- 6' 2-1/2"
- 5' 8-1/2"
- 5' 2-1/2"



WHILE WE WERE BOWLING

Neon Specs

SHEET 16

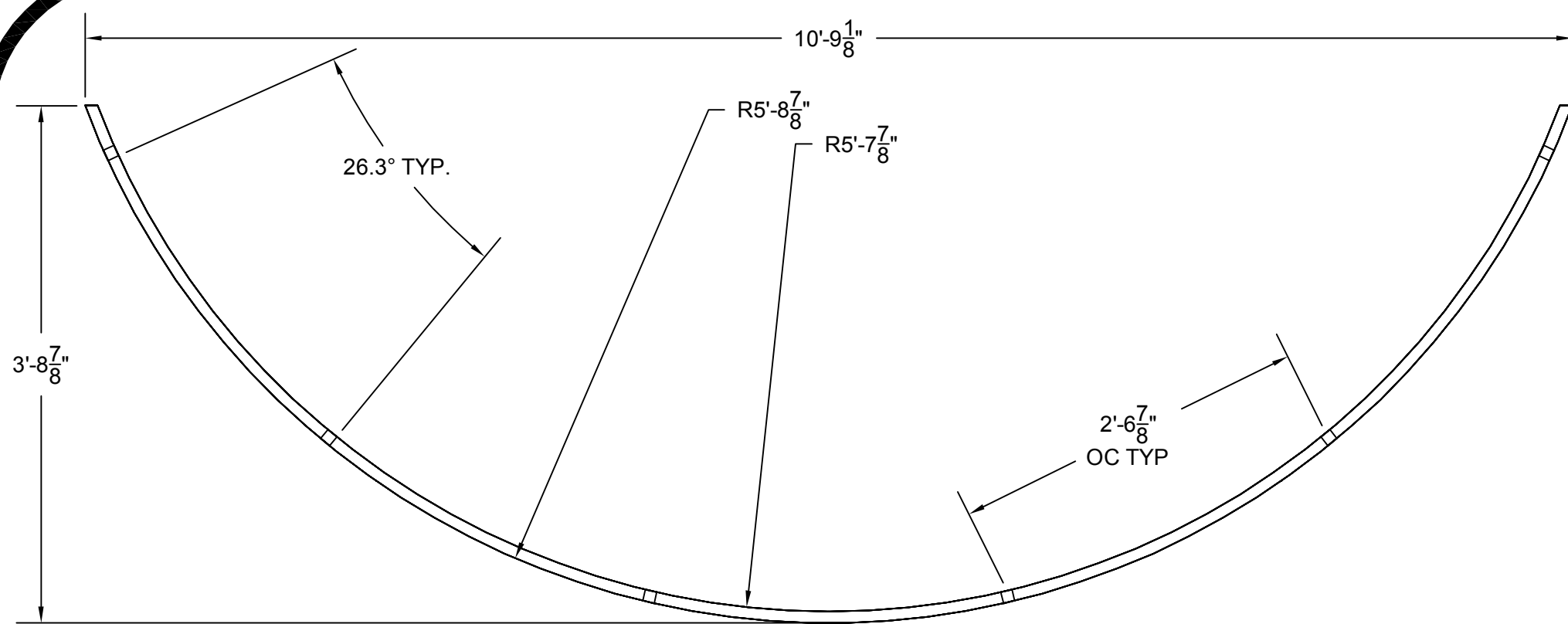

TOP VIEW

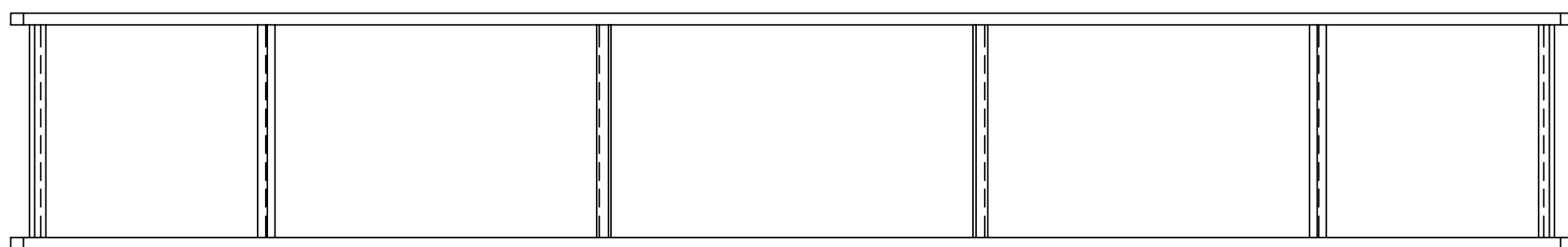

FRONT VIEW

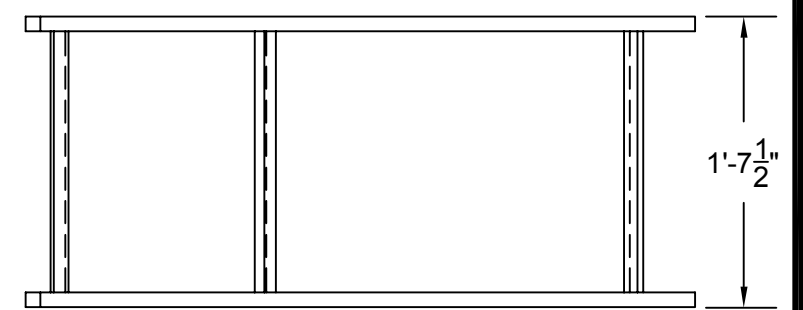

SIDE VIEW

CURVED HEADER - METAL FRAMING
BUILD 2

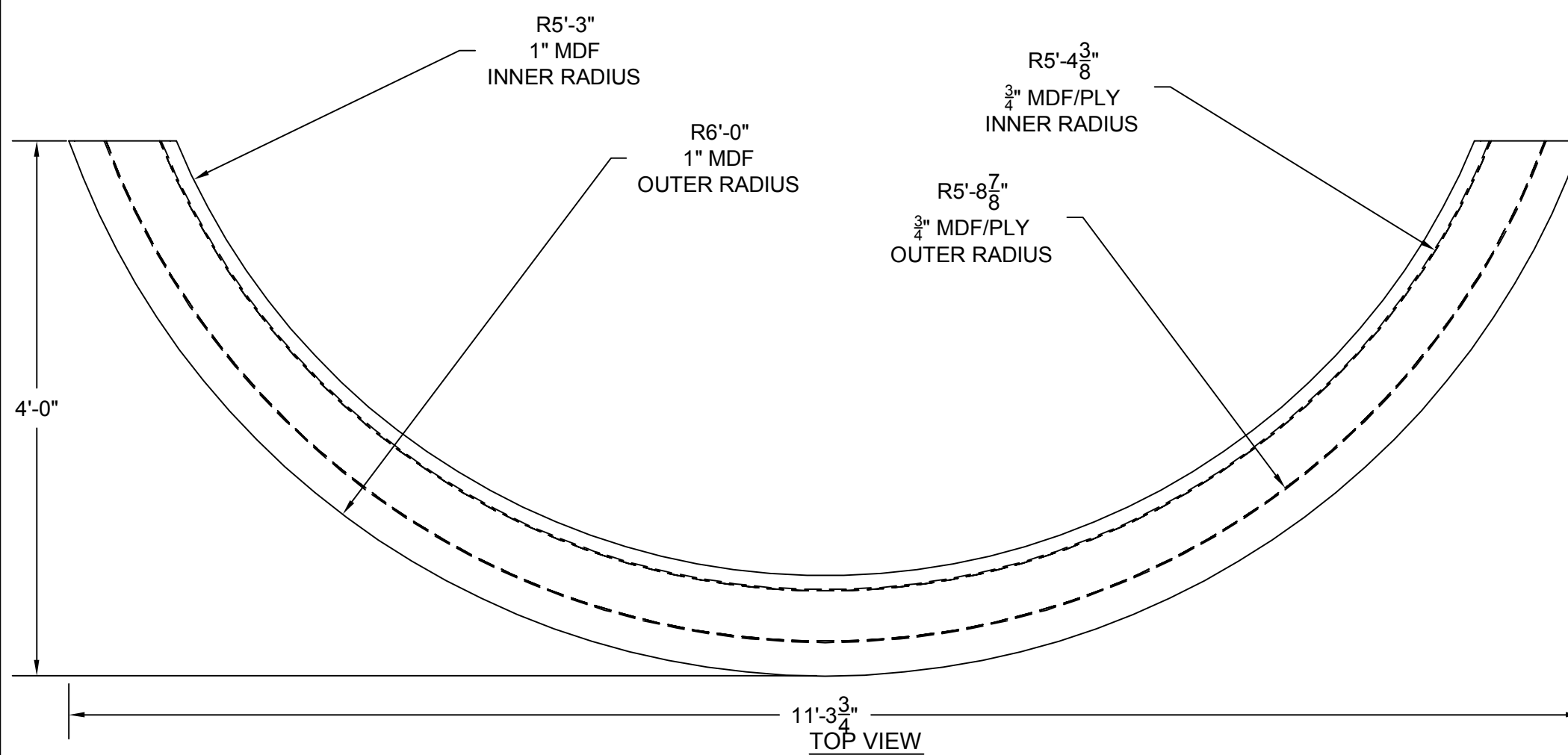

TOP VIEW

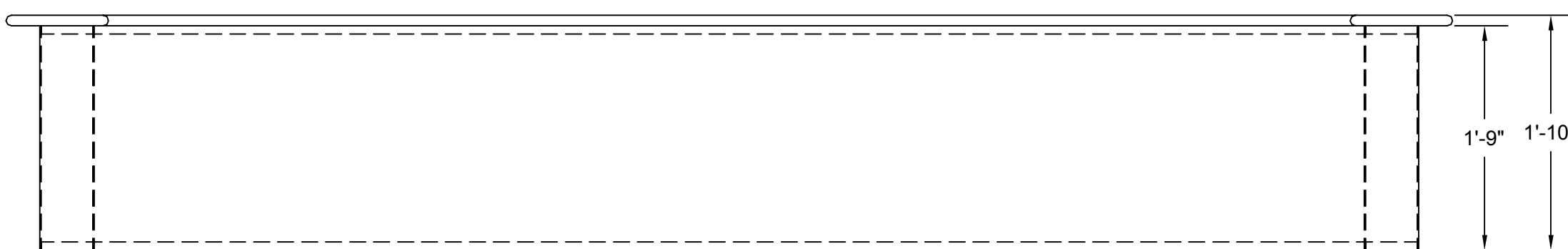

FRONT VIEW

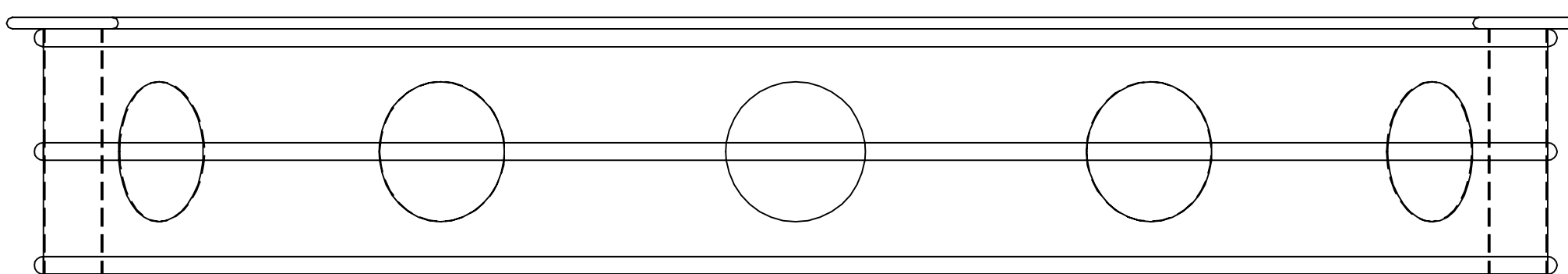

FRONT VIEW
WITH TRIM AND PLEXI

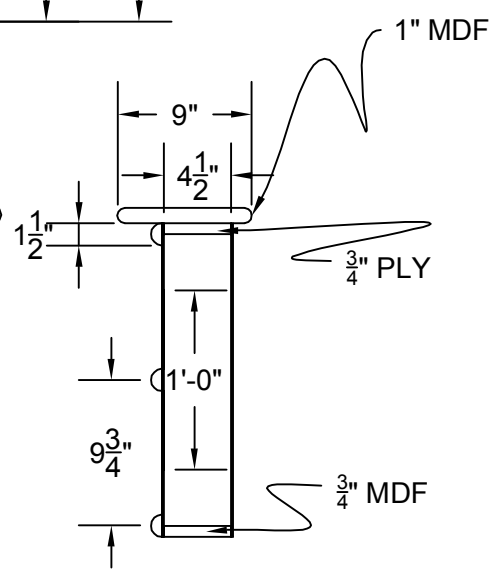

SIDE VIEW

CURVED HEADER
BUILD 2

General Notes

SKIN WITH 1/8" LAUAN
ASSUME ALL BUT MDF (AND
STEEL) IS STAINED UNLESS
TOLD OTHERWISE (I'LL LET
YOU KNOW AS SOON AS I DO)
1 1/2" HALF ROUND TO BE MADE
FROM 2x6

DIRECTOR GAVIN CAMERON-WEBB

DESIGNER RUSSELL METHENY

TD CHRIS NOBLE

DRAWN BY NOBLE



BOWLING
CURVED HEADERS

STUDIO ARENA THEATRE
710 MAIN ST
BUFFALO, NY 14202

Project CURVED HEADERS

Date 1.16.04

Scale 1"=1'-0"

Sheet

17

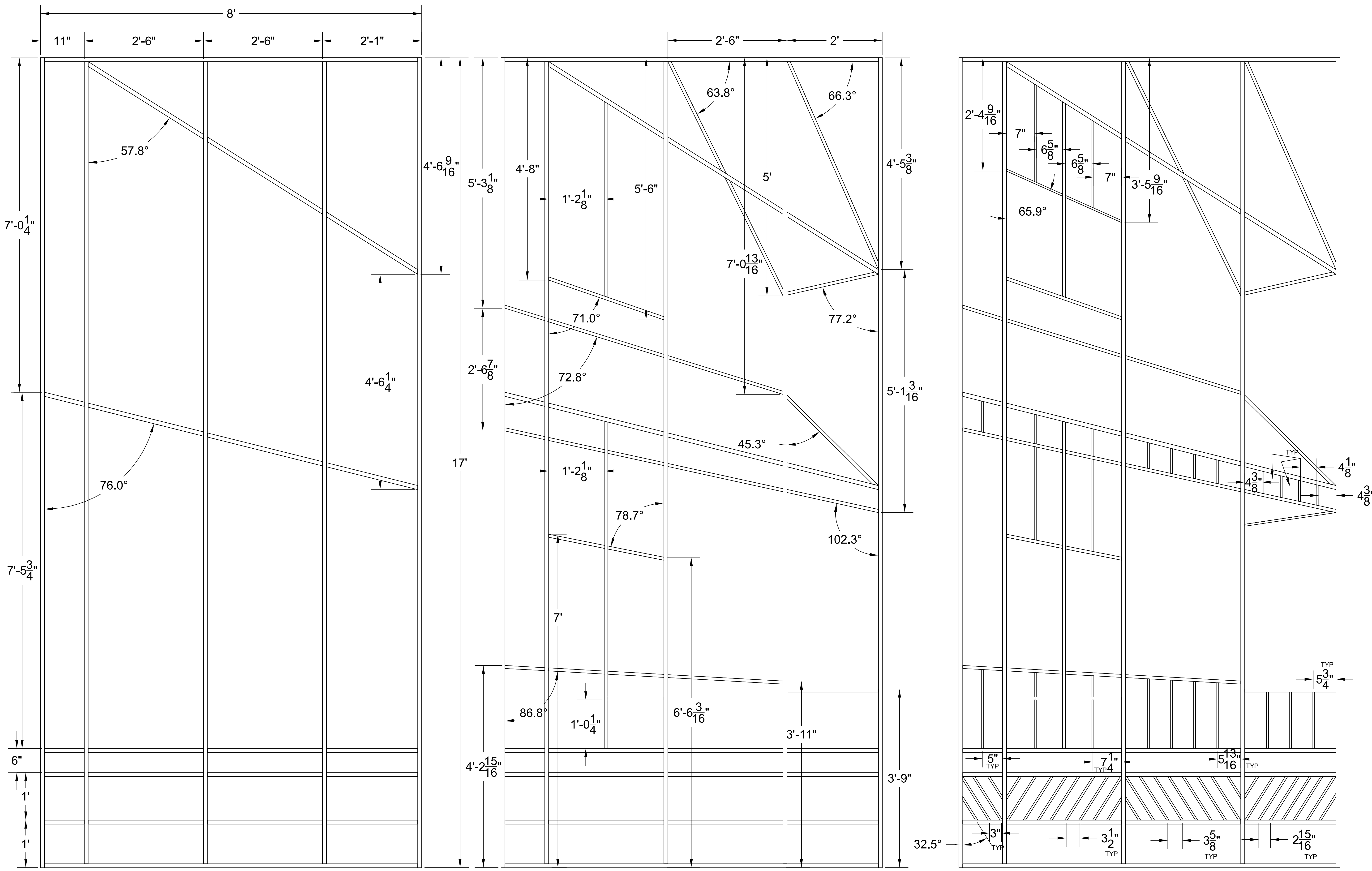

SR TRACKING PANEL
1" BOX

SR TRACKING PANEL
3/4" BOX

SR TRACKING PANEL
1/2" BOX

AFTER STEEL STRUCTURE IS WELDED A NAILING STRIP (1/4" PLY) NEEDS TO ADDED TO THE BACK OF THE STEEL.

SCRIM WILL BE ADDED AT A LATER DATE

3 SCENERY CARRIERS WILL BE ATTACHED AT THE TOP

3 WHEELS WILL BE BOLTED ON THE BOTTOM OF THE BACK

2 KNIVES WILL ALSO BE ATTACHED AT BOTH ENDS

- MATERIALS:
 8 1" BOX TUBE
 4 3/4" BOX TUBE
 5 1/2" SQUARE ROD
 1/2 SHT 1/4" PLY

DIRECTOR	GAVIN CAMERON-WEBB
DESIGNER	RUSSELL METHENY
TD	CHRIS NOBLE
DRAWN BY	AMY MYERS



WHILE WE WERE BOWLING
 SR TRACKING PANEL
 STUDIO ARENA THEATRE
 710 MAIN ST
 BUFFALO, NY 14202

Project	TRACKING PANELS	Sheet	19
Date	1.15.04		
Scale	1"=1'-0"		

ATTACHES TO SIDE PIECES
WITH 5/16" FHS BOLTS

**ARC LENGTH 4'-11⁵/₈"
CENTER TO CENTER
ON RINGS AND POSTS**

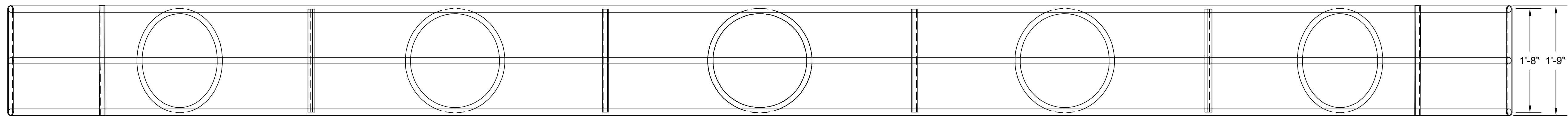
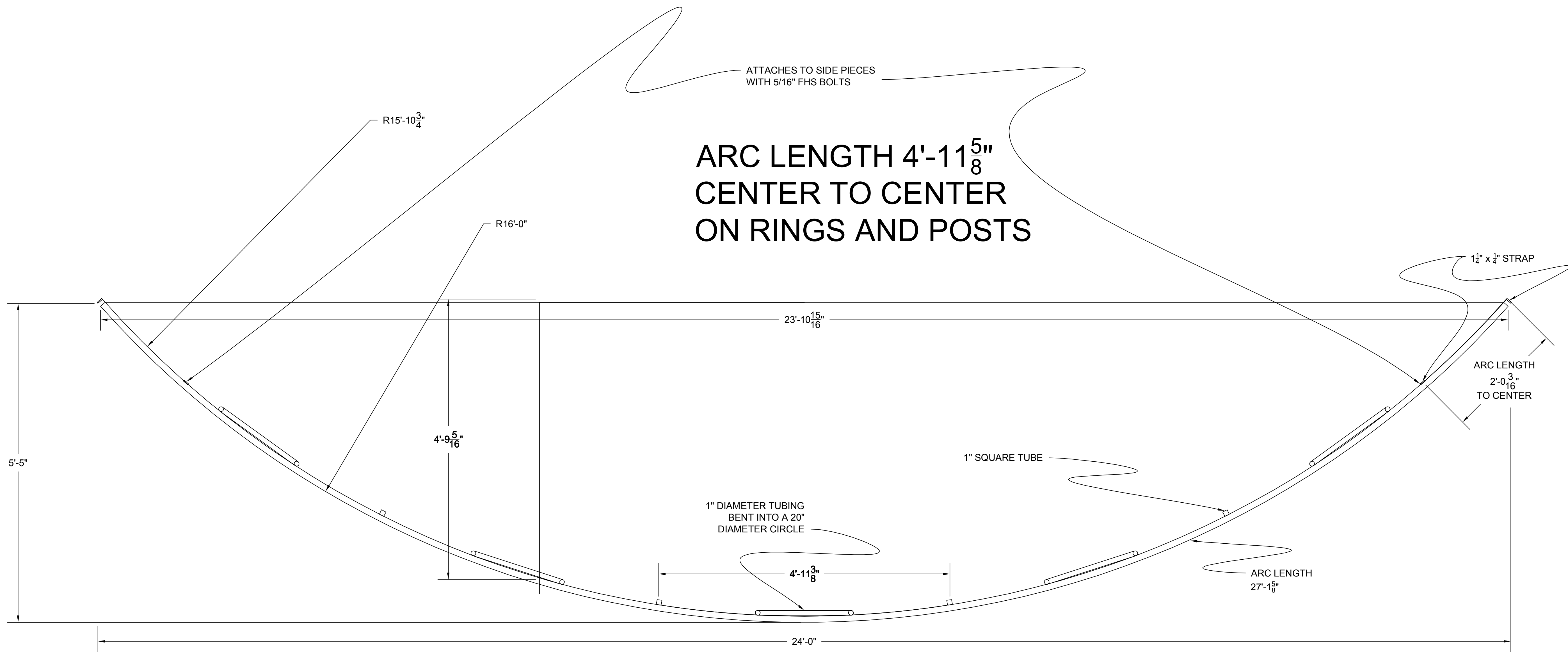

General Notes

MATERIALS:
 1 1/4" ROUND TUBE
 1" SQUARE TUBE
 20" PRE-BENT RINGS
 1 1/4" x 1/4" FLAT STOCK

DIRECTOR	GAVIN CAMERON-WEBB
DESIGNER	RUSSELL METHENY
TD	CHRIS NOBLE
DRAWN BY	NOBLE



**BOWLING
ARTICULATING
HEADER FRONT PIECE**

STUDIO ARENA THEATRE
710 MAIN ST
BUFFALO, NY 14202

Project	ART. HEADER FRONT	Sheet	21
Date	1.21.04		
Scale	1"=1'-0"		

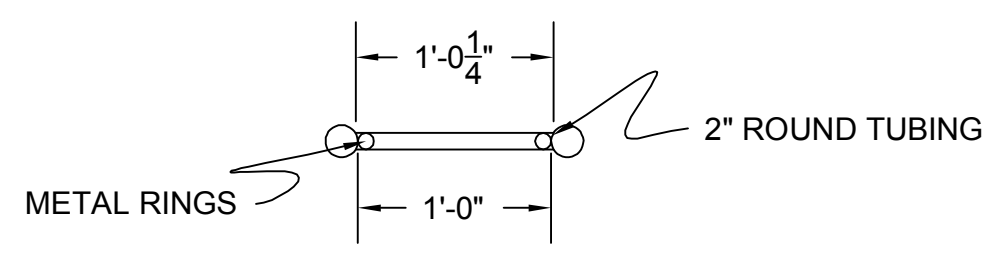
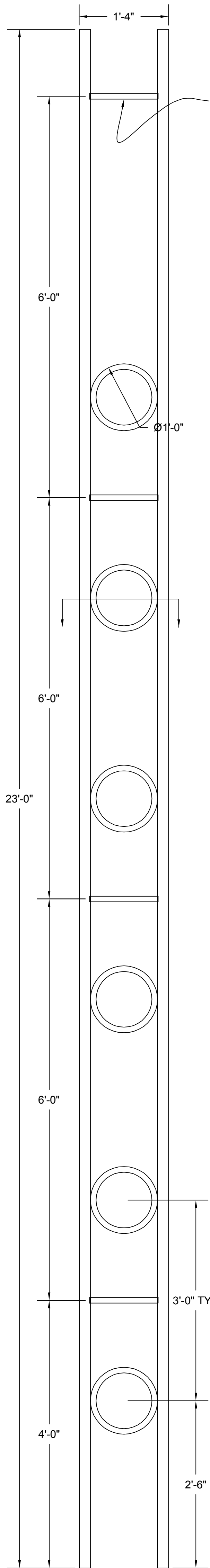

SECTION

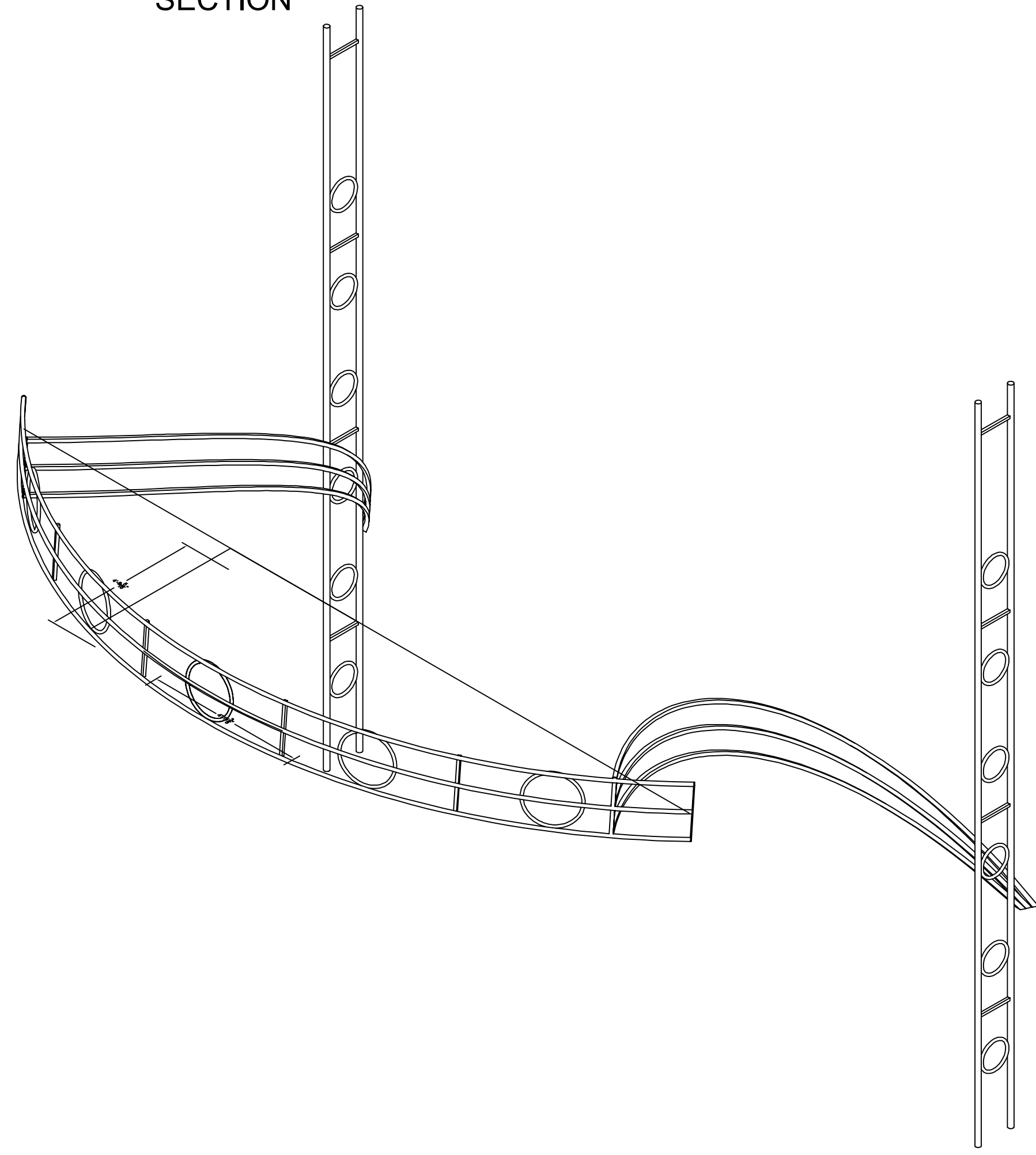

General Notes

MATERIALS:
 2" ROUND TUBE
 1" SQUARE TUBE
 12" PRE-BENT RINGS

BUILD TWO

DIRECTOR	GAVIN CAMERON-WEBB
DESIGNER	RUSSELL METHENY
TD	CHRIS NOBLE
DRAWN BY	NOBLE



**BOWLING
 ARTICULATING
 HEADER POSTS**

STUDIO ARENA THEATRE
 710 MAIN ST
 BUFFALO, NY 14202

Project	ART. HEADER POST	Sheet	22
Date	1.23.04		
Scale	1"=1'-0"		

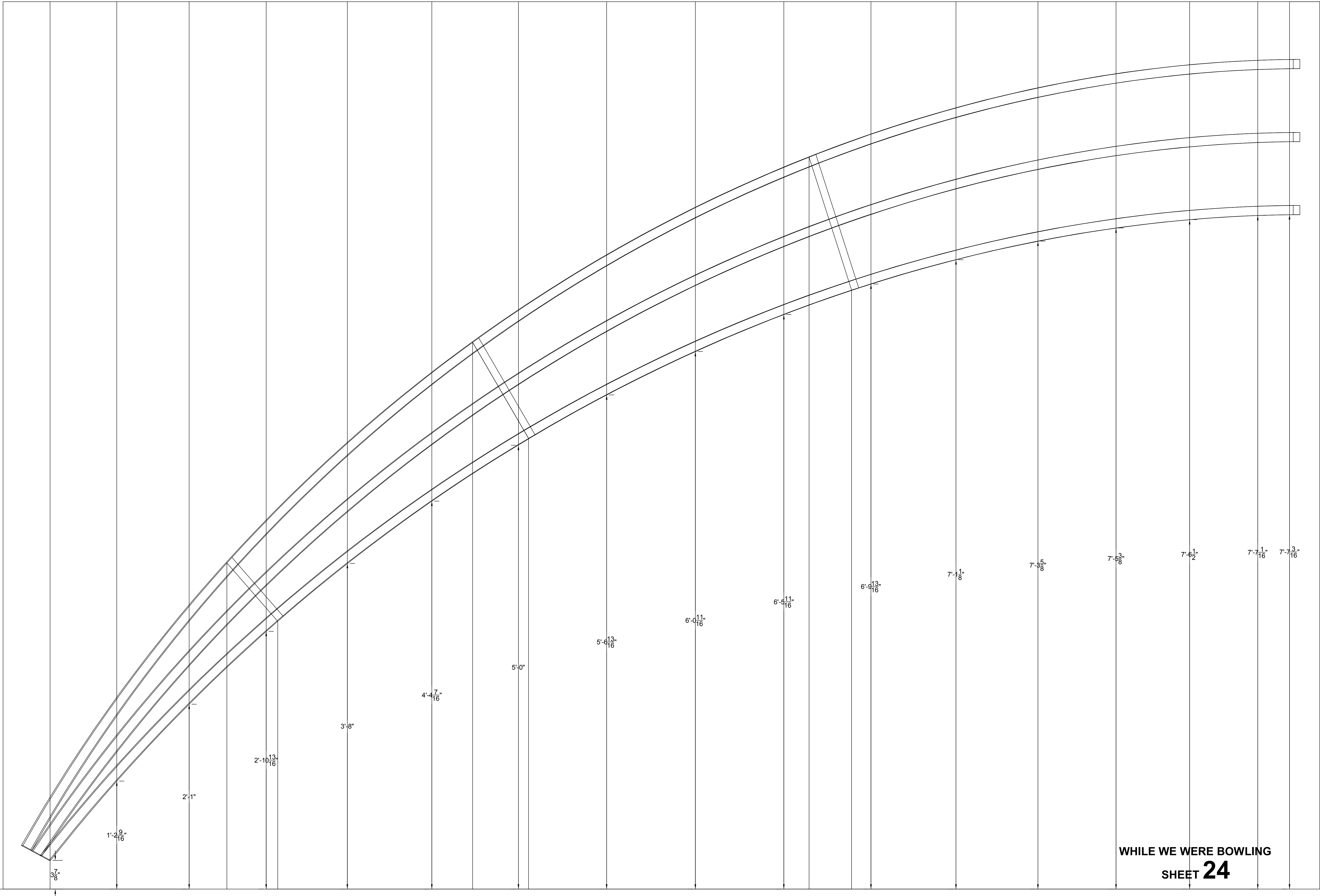

WHILE WE WERE BOWLING
 SHEET **24**

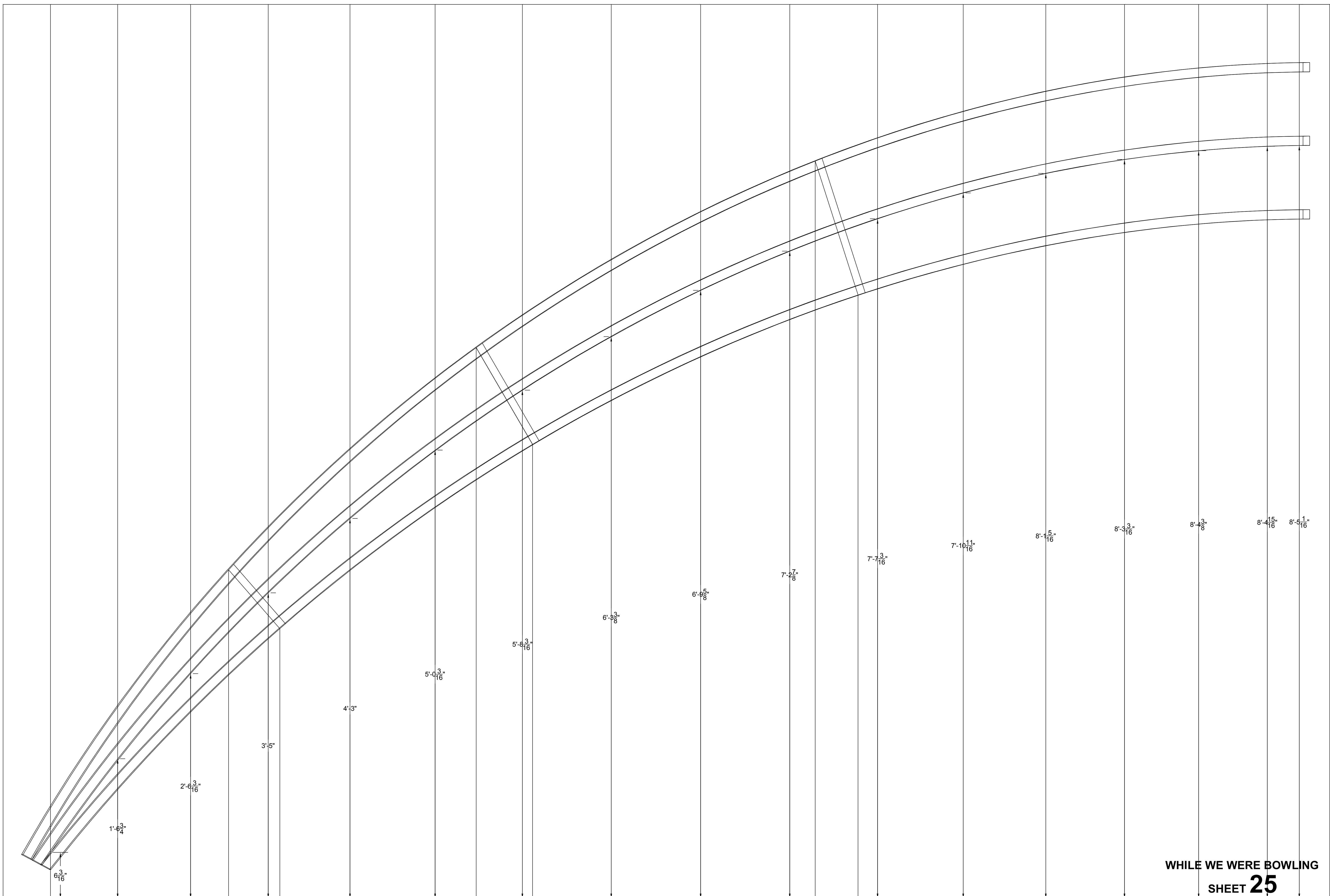

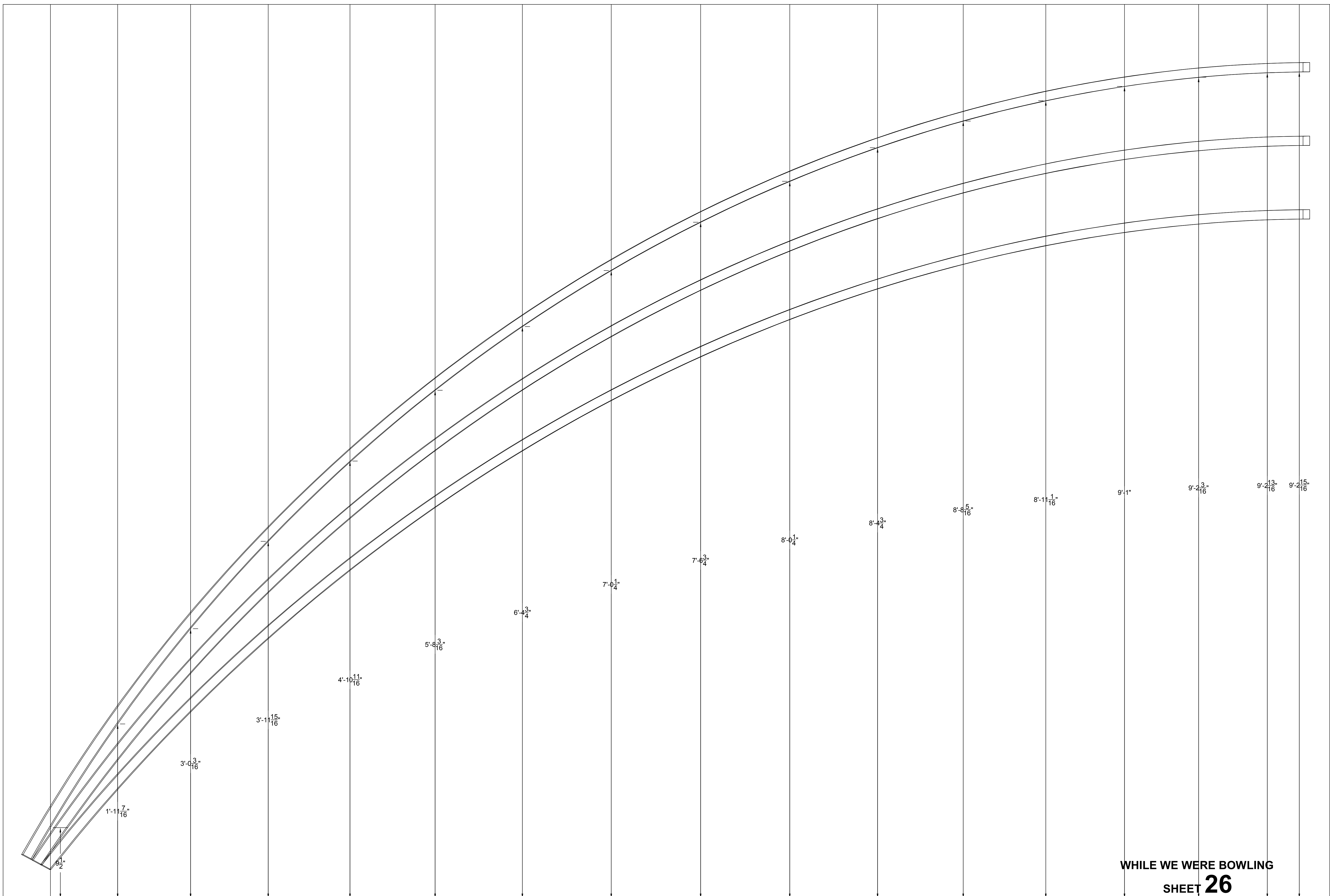

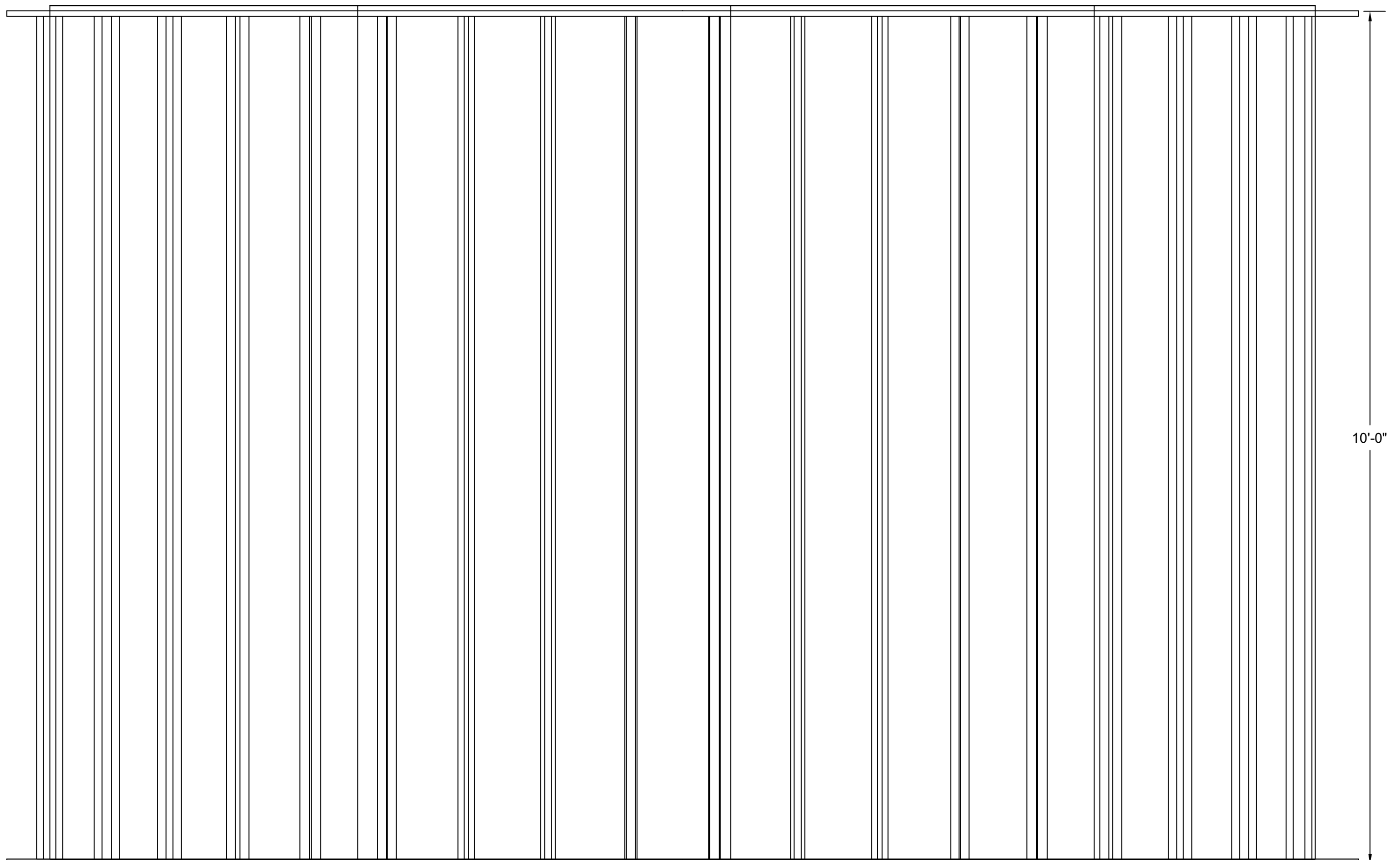
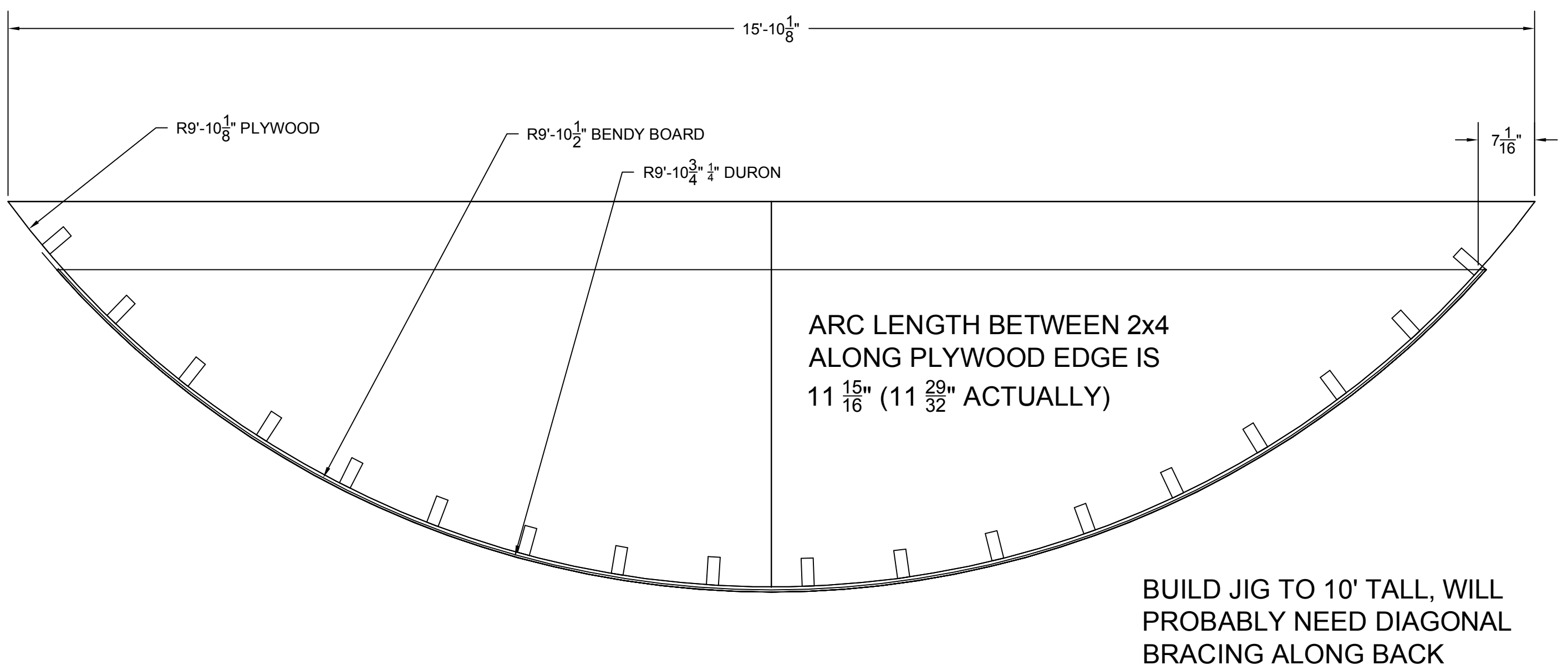

ARTICULATING HEADER JIG (FOR SIDE PIECES)

SHEET 1 OF 4

SCALE 1"=1'-0"

BUILD FRAME WITH $\frac{3}{4}$ " PLY AND 2x4
SKIN WITH $\frac{3}{8}$ " BENDY BOARD AND $\frac{1}{4}$ " DURON



WHILE WE WERE BOWLING

SHEET **23**

DIMENSIONS ARE ARC
LENGTHS ALONG BASE OF
CURVE.

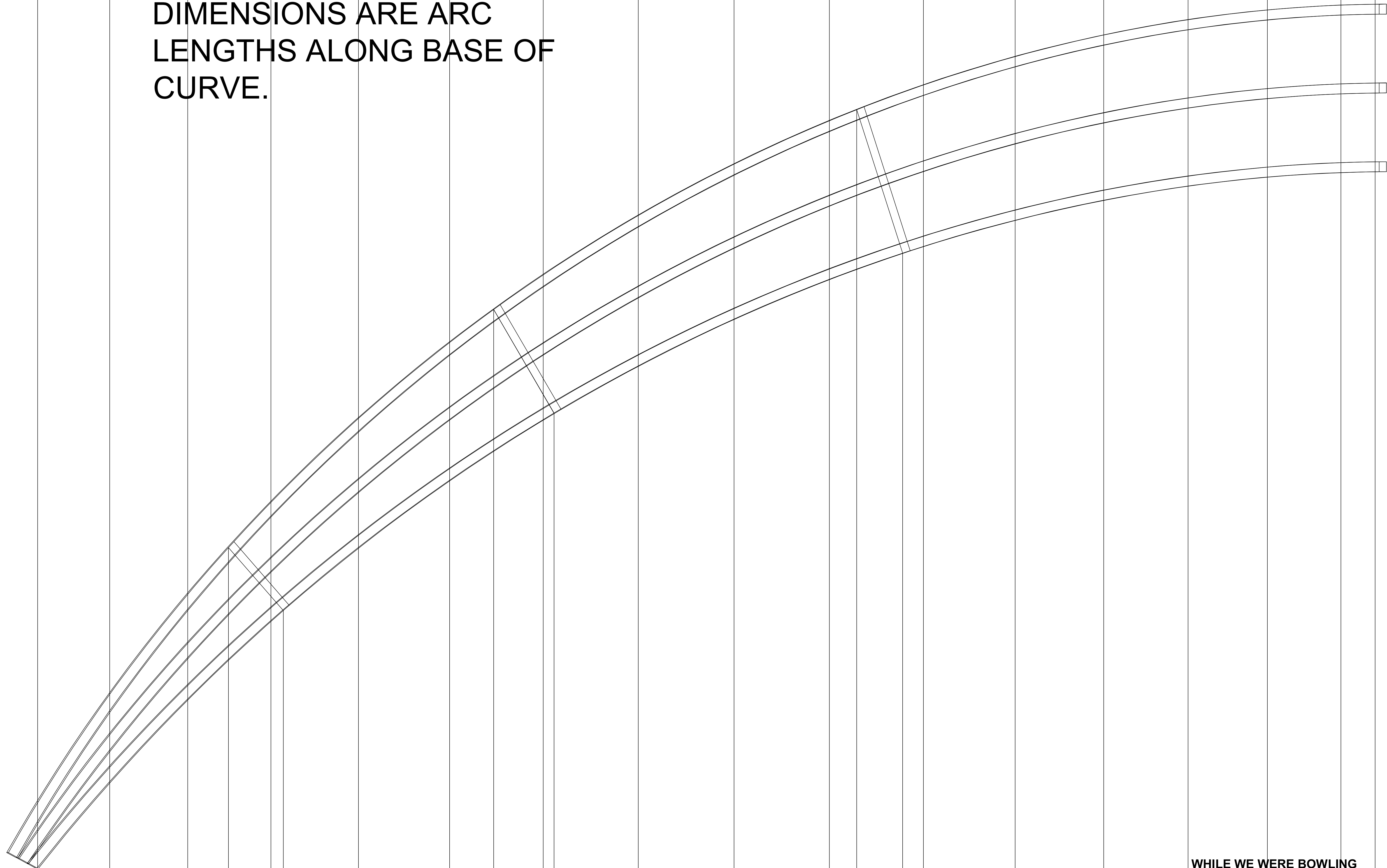

BEND 4

SCALE: 3"=1'-0"

USE $\frac{3}{4}$ " 16 GAUGE
ROUND TUBING

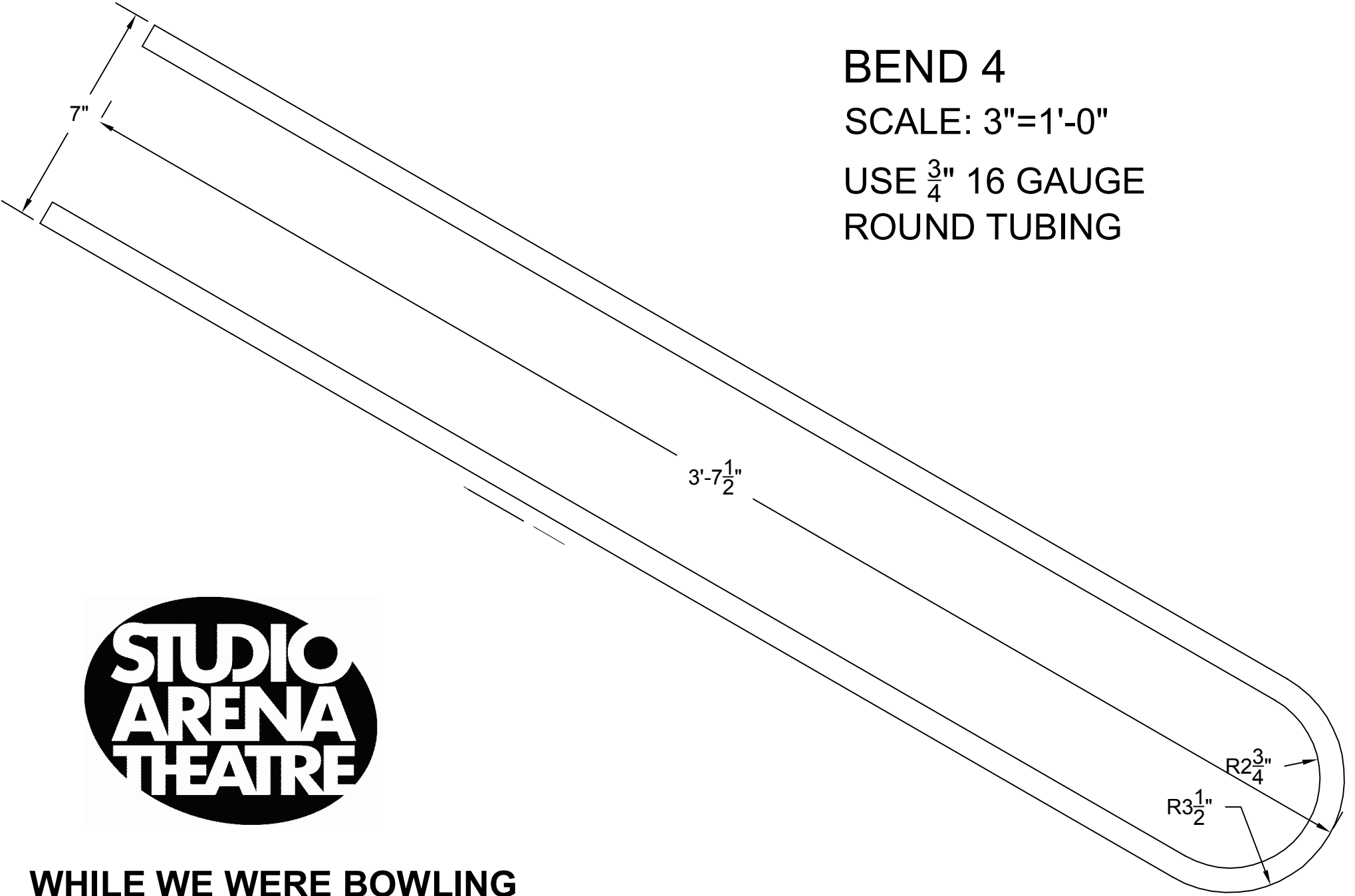

WHILE WE WERE BOWLING

SHEET **28**

BUILD 2

UNITS ARE COMPLETE AND SYMETRICAL

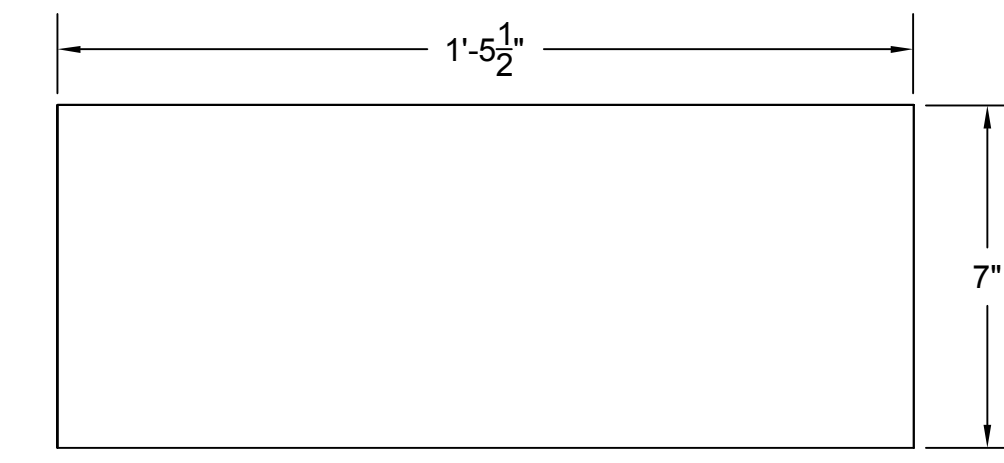
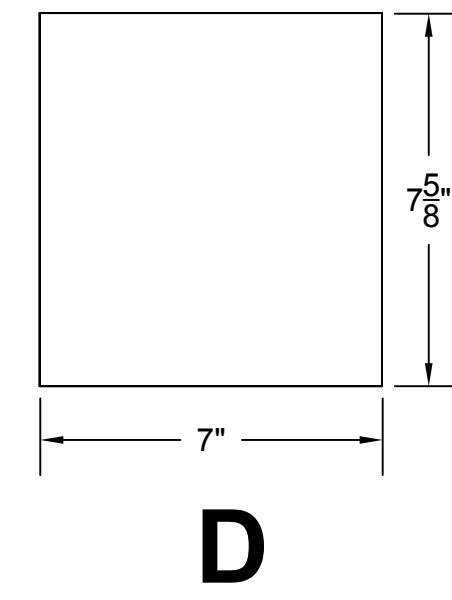
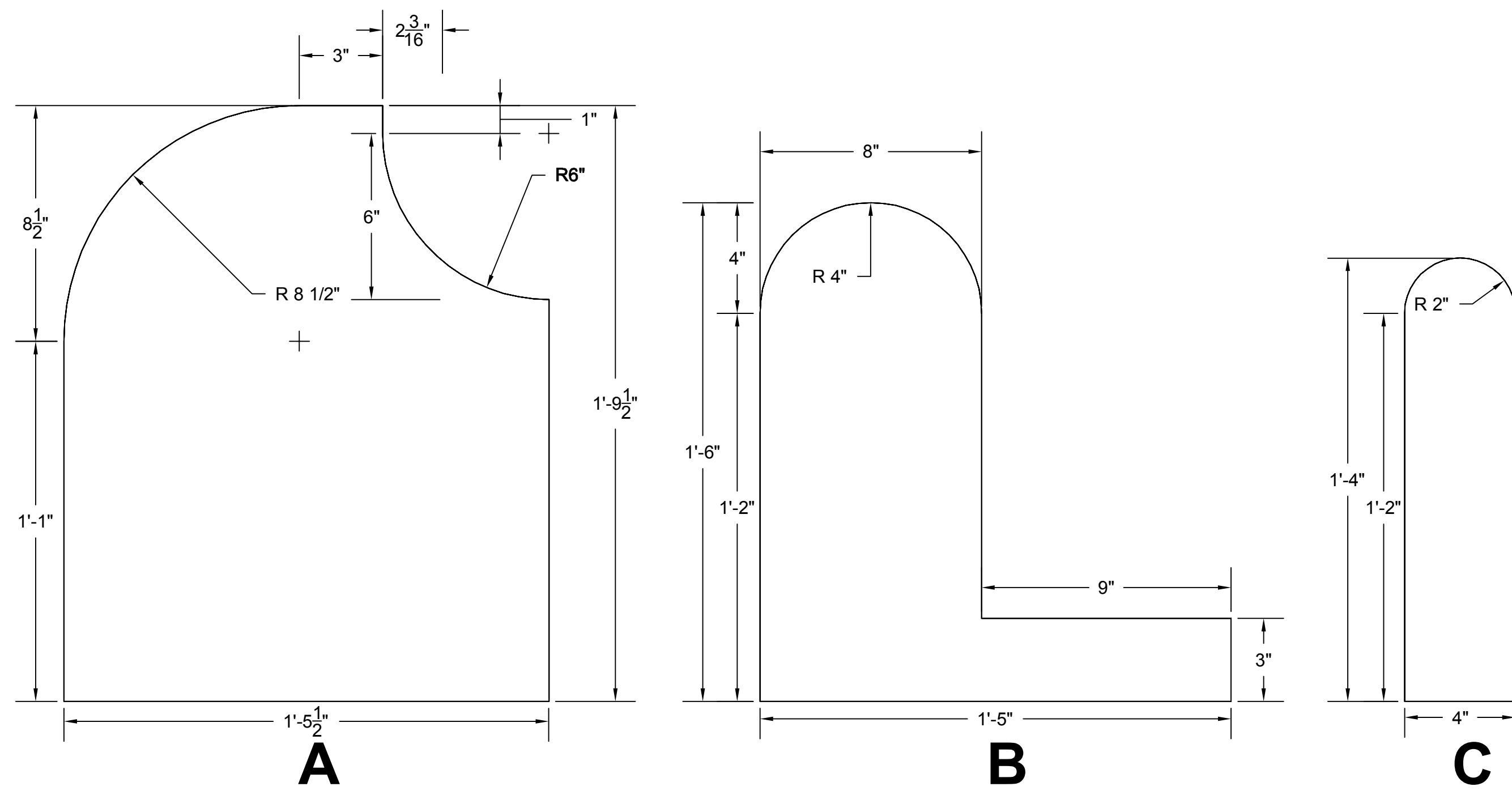

BASE OF UNIT
USE $\frac{3}{4}$ " PLYWOOD

A- D ARE CUT FROM 1/2" MDF

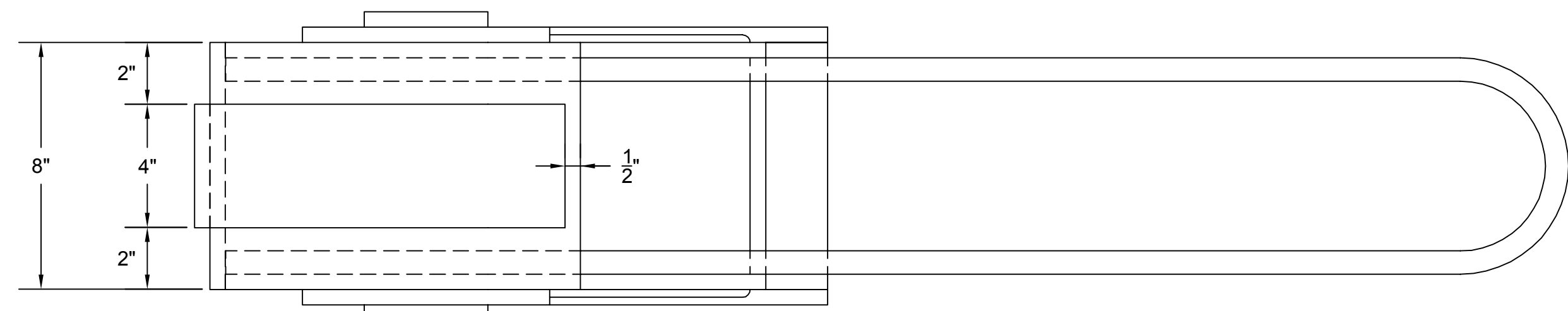

TOP VIEW

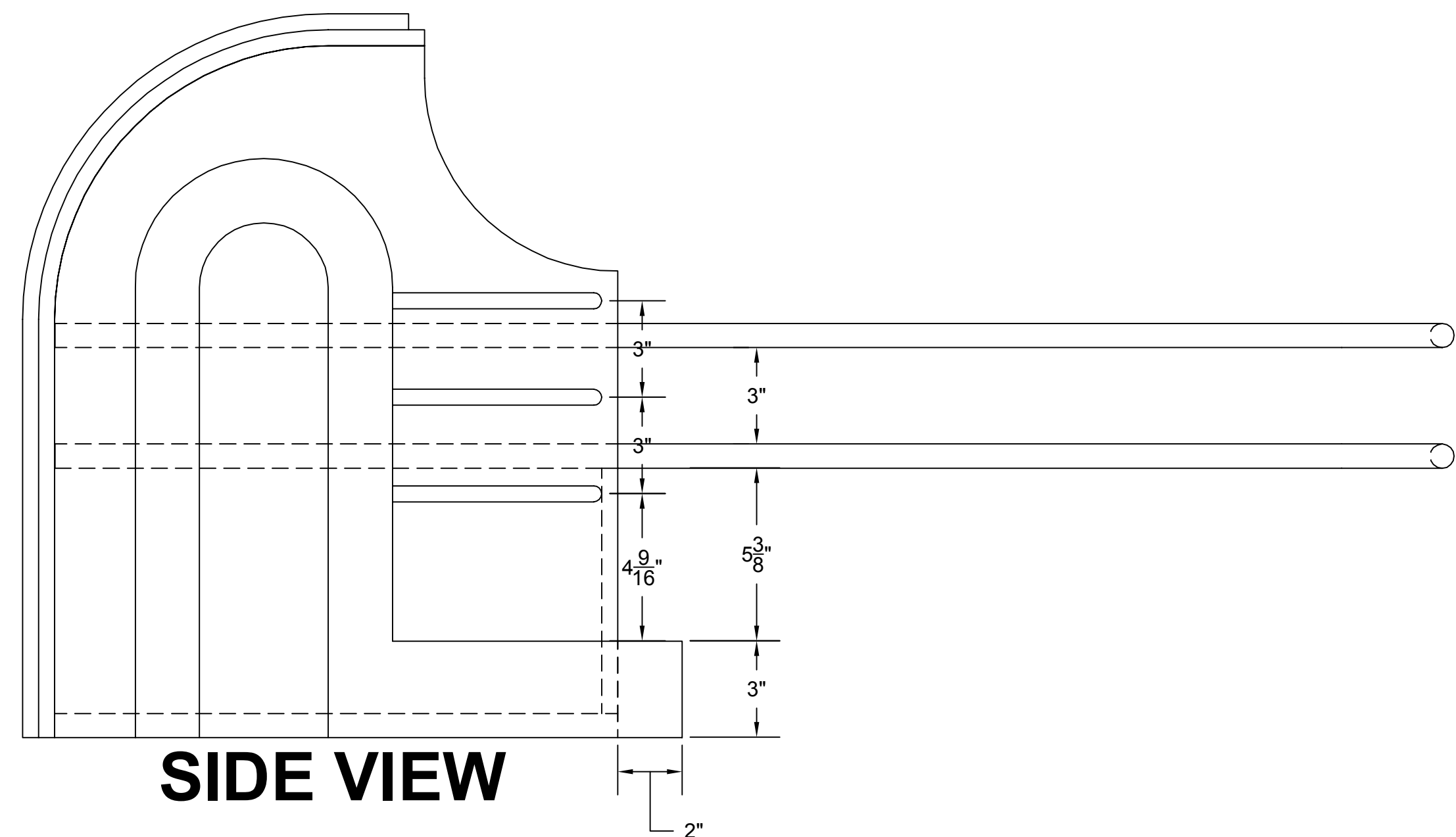

SIDE VIEW

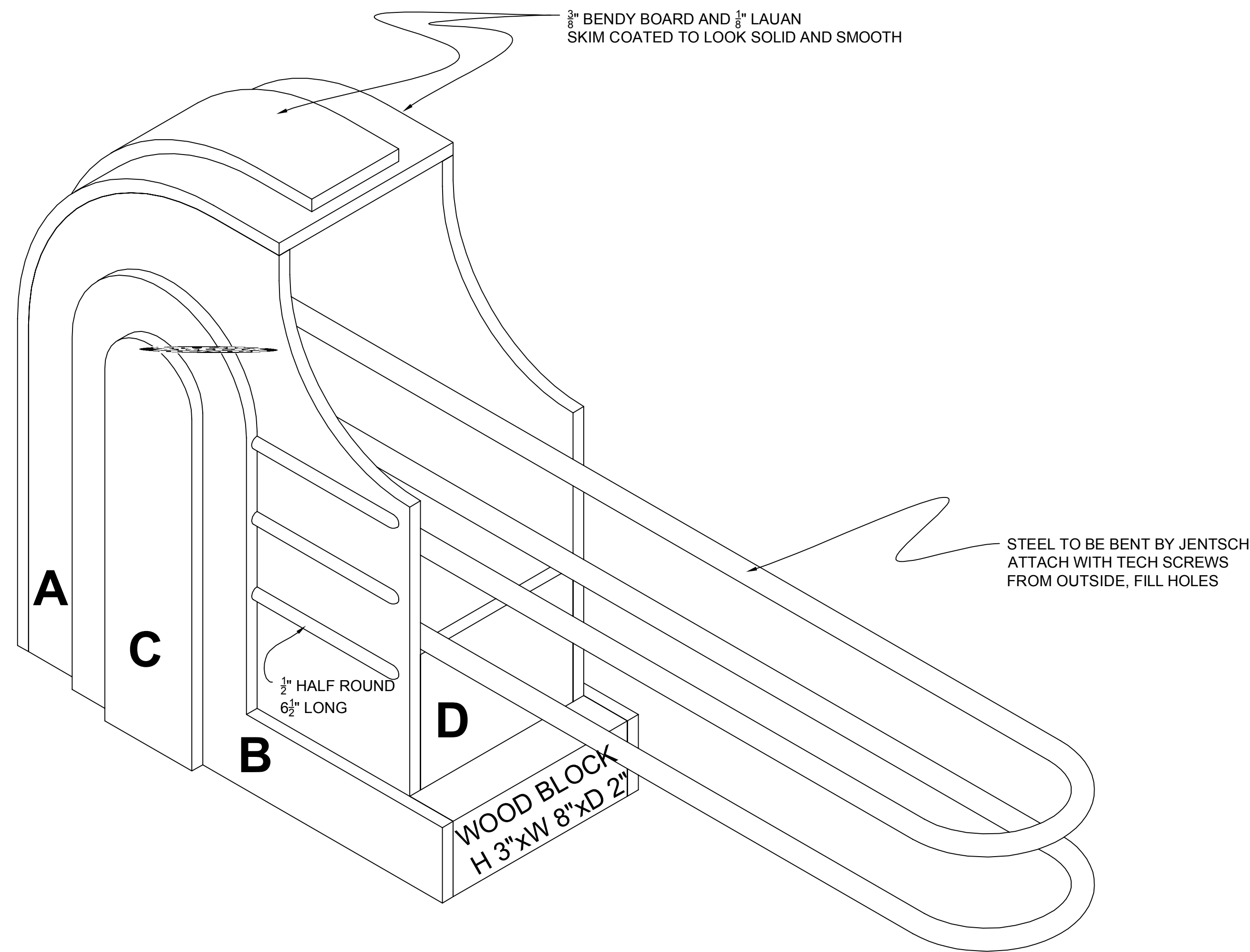

ISOMETRIC VIEW

General Notes

MATERIALS:

- $\frac{3}{4}$ " ROUND TUBE
- $\frac{1}{2}$ " MDF
- $\frac{3}{8}$ " PLYWOOD
- $\frac{1}{8}$ " LAUAN
- $\frac{5}{8}$ " BENDABLE PLY
- SCRAP WOOD

NOTES:

- FILL ALL HOLES, SEAMS AND GRAIN
- UNIT TO BE PAINTED TO LOOK LIKE METAL

DIRECTOR	GAVIN CAMERON-WEBB
DESIGNER	RUSSELL METHENY
TD	CHRIS NOBLE
DRAWN BY	NOBLE



BOWLING BALL RETURN
STUDIO ARENA THEATRE
710 MAIN ST
BUFFALO, NY 14202

Project	BALL RETURN	Sheet	29
Date	1.22.04		
Scale	3"=1'-0"		

THESE ARE LIGHT BOXES, SO FRONT AND BACK WILL BE SKINNED WITH LAUAN (DON'T ROUND SEAMS ON BACK LAUAN...)

BUILD 2 R&R

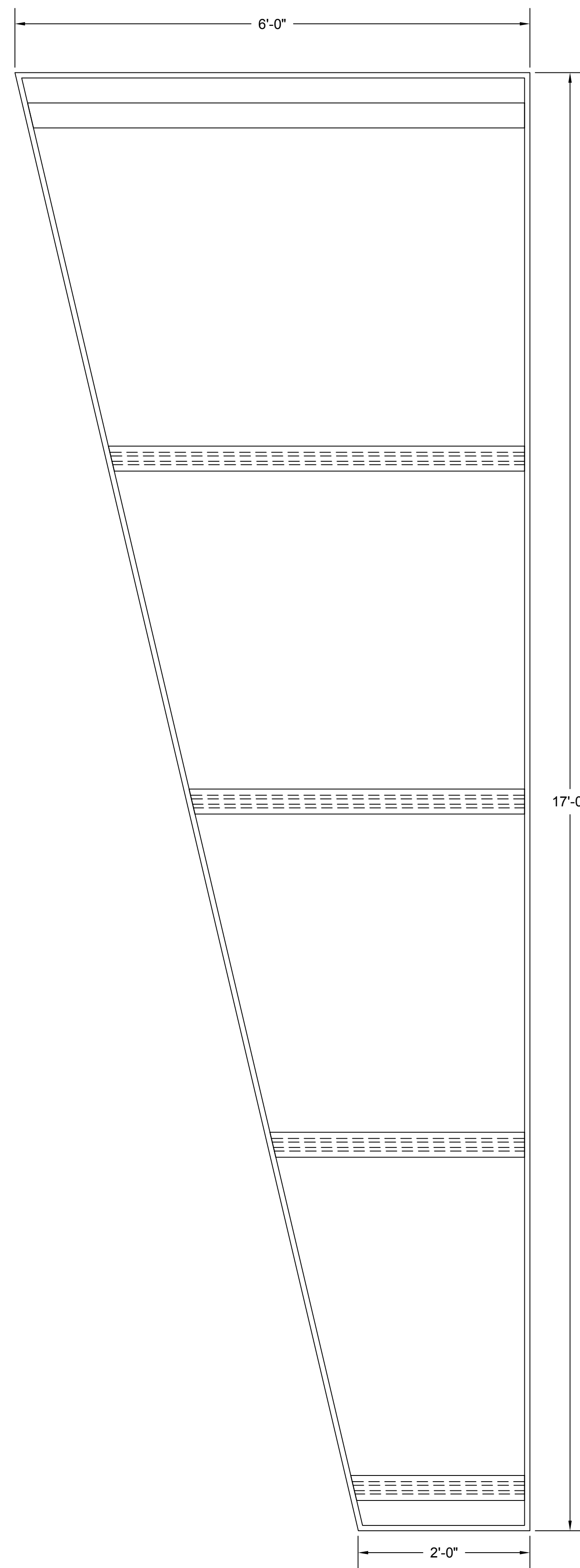

FRONT
FRAMING
SR UNIT

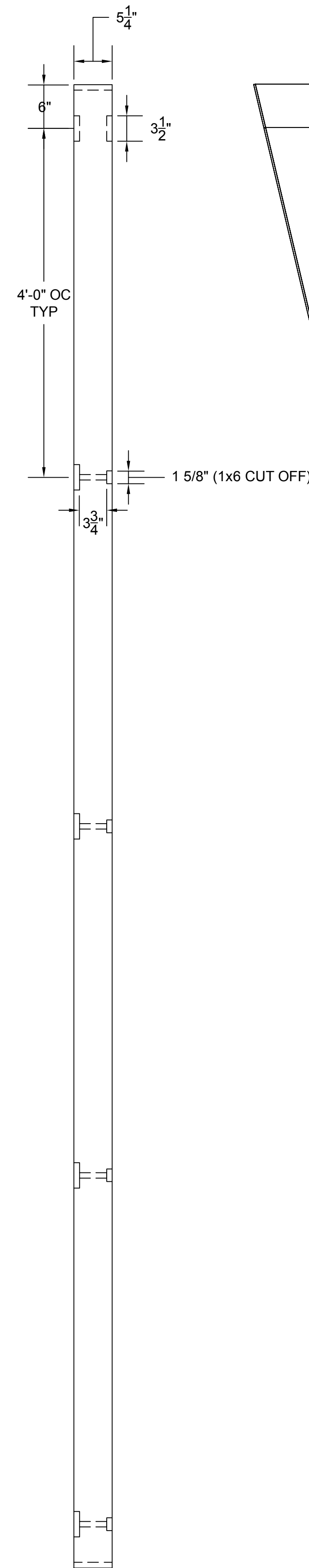

SIDE

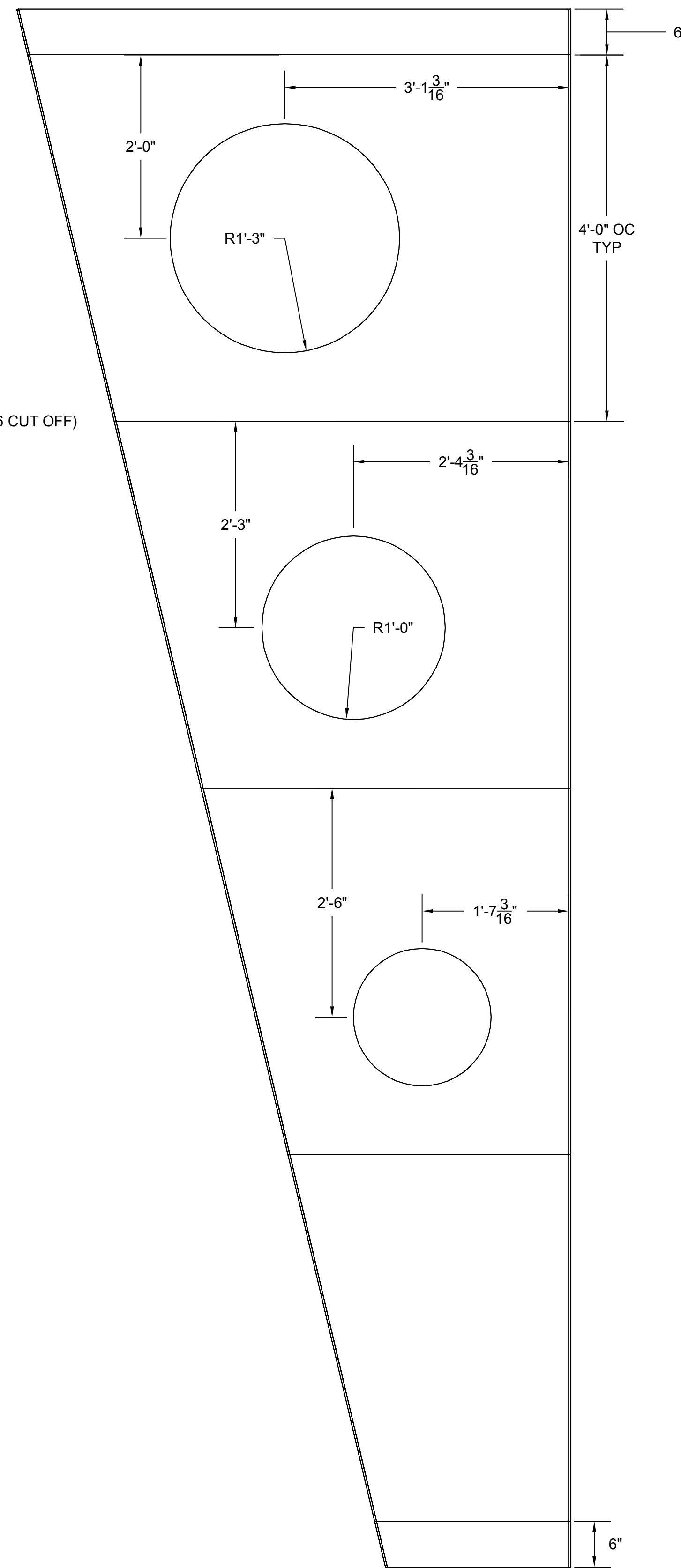

FRONT
LAUAN
SR UNIT

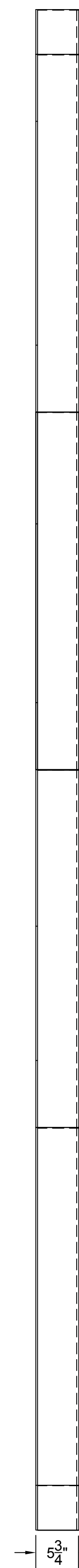

SIDE

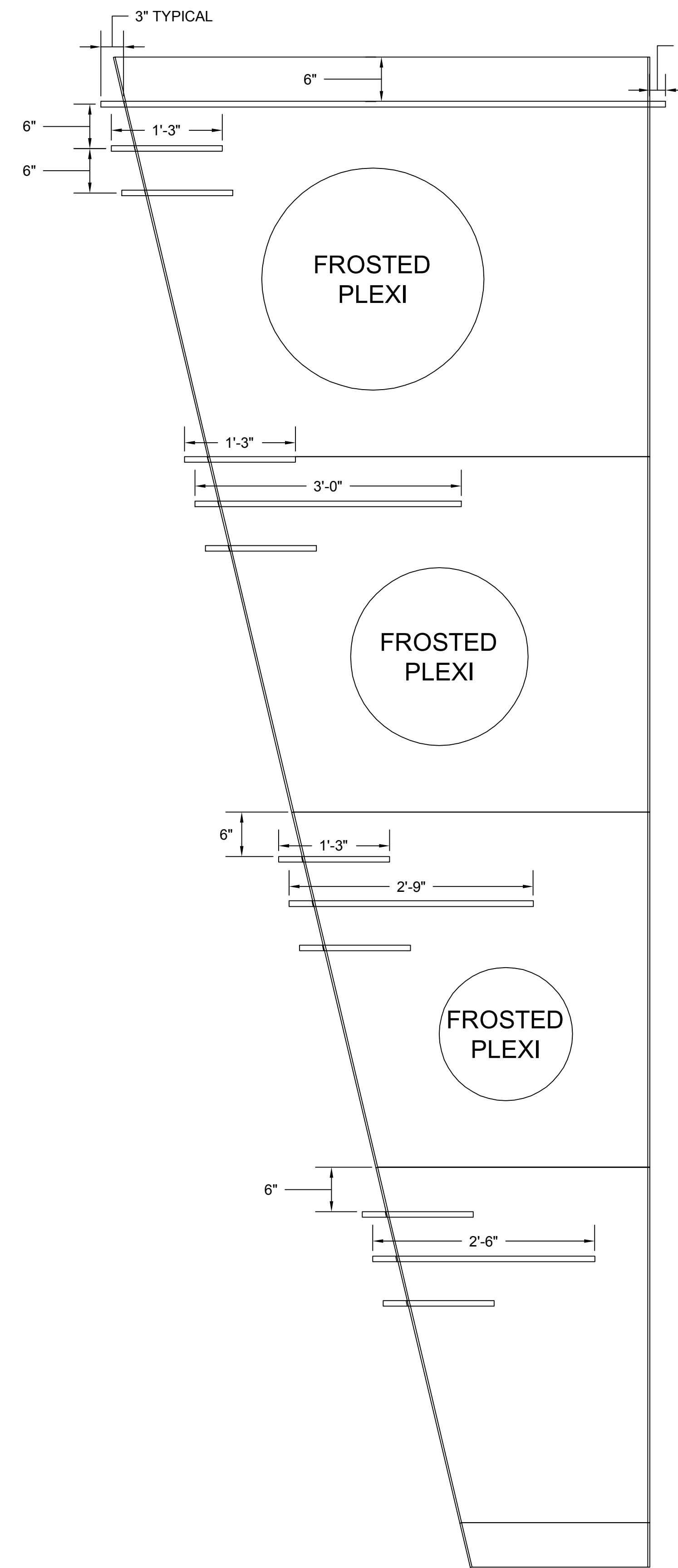

FRONT
LAUAN W/ TRIM
SR UNIT

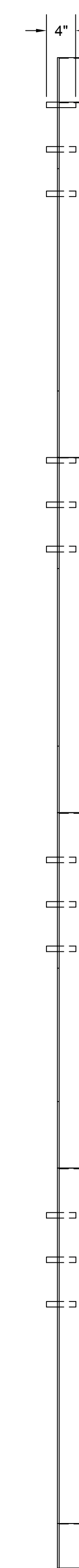

SIDE

General Notes

- MATERIALS:**
 1/4" LAUAN
 1/8" FROSTED PLEXI
 1/16" CLEAR PLEXI
 1x4
 1x6

- NOTES:**
 GRAIN TO RUN HORIZONTAL.
 PLEASE NOTE LAUAN FACES ON SIDES OF UNIT. ALL LAUAN SEAMS TO BE ROUNDED OVER. SEE VOLKER DRAWINGS FOR EXAMPLE.
 TRIM TO BE PAINTED TO LOOK LIKE METAL

DIRECTOR	GAVIN CAMERON-WEBB
DESIGNER	RUSSELL METHENY
TD	CHRIS NOBLE
DRAWN BY	NOBLE



BOWLING PROSCENIUM FACADES
 STUDIO ARENA THEATRE
 710 MAIN ST
 BUFFALO, NY 14202

Project	PROSCENIUM FACADES	Sheet	30
Date	1.23.04		
Scale	1"=1'-0"		